



# *MST326*

## *Revision Booklet*

---

### *Contents*

<b>Introduction</b>	<b>2</b>
<b>1 Ordinary differential equations</b>	<b>3</b>
1.1 Separation of variables	3
1.2 Integrating factor method	5
1.3 Which method to use?	6
1.4 Second-order equations	7
<b>2 Functions of more than one variable</b>	<b>10</b>
2.1 Partial differentiation	10
2.2 Taylor polynomials	11
2.3 The Chain Rule	13
<b>3 Vector algebra and calculus</b>	<b>14</b>
3.1 Addition, scalar and vector products	14
3.2 Position, velocity and acceleration	16
3.3 Gradient of a scalar field	18
3.4 Divergence and curl of a vector field	19
<b>4 Integration of scalar and vector fields</b>	<b>20</b>
4.1 Line integrals	20
4.2 Surface integrals	22
4.3 Volume integrals	23
<b>5 Dimensions</b>	<b>25</b>
5.1 Dimensional consistency	25
5.2 Dimensional analysis	27
<b>Solutions to the exercises</b>	<b>29</b>
<b>Index</b>	<b>36</b>

# Introduction

The purpose of this *Revision Booklet* is to remind you of the important techniques which are assumed as background material for the course. You should have met all the material in this booklet in previous courses, so the exercises may be treated as revision. They are designed to give you practice at those techniques for which you might be rusty, and to help you to ‘warm up’ for the course.

This booklet contains no theory or explanation of why the methods for solving particular problems are chosen. However, some references are given below. Each subsection (except 1.3) is divided into three parts:

- (a) a *worked example*, showing the procedure to adopt when solving problems of the type given;
- (b) a *structured exercise* for you to attempt, with questions or instructions to guide you to the answer; (These questions are typical of what you should ask yourself when solving similar problems. They are based on the procedure boxes of MST209. Full solutions to these exercises are given at the back of the booklet.)
- (c) one or more *further exercises* for you to try. (Some of these exercises occur again in Block 1 of the course. Only the answers to these exercises, not full solutions, are given at the back.)

The following table lists the techniques that are revised in this booklet, and where the background theory can be found.

Technique to be revised	Section	MST209 reference
Ordinary differential equations	1	First-order: <i>Unit 2</i> Second-order: <i>Unit 3</i>
Functions of more than one variable	2	<i>Unit 12</i>
Vector algebra and calculus	3	<i>Units 4, 23, 24</i>
Integration of scalar and vector fields	4	<i>Units 24, 25</i>
Dimensions	5	<i>Unit 16</i>

If in attempting the further exercises you become stuck, then refer to the appropriate units of the prerequisite course(s) that you studied.

It is best to begin each section by attempting the worked example as an exercise. If you find this difficult, then study the solution to the worked example and attempt the following structured exercise. Otherwise, move on to the further exercises.

The booklet is best worked through before the beginning of the course. However, if you prefer, it is possible to work through different sections during the study of early units, as indicated in the following table.

MST326 Unit	Study this material in the <i>Revision Booklet</i> first
1	1.1–1.3: Ordinary differential equations of first order 4.2: Surface integrals
2	1.4: Ordinary differential equations of second order
3	2: Partial differentiation and the Chain Rule
4	3: Vector algebra and calculus 4: Line, surface and volume integrals
6	5: Dimensions

# 1 Ordinary differential equations

## 1.1 Separation of variables

### Example 1.1

Find the particular solution of the differential equation

$$\frac{dy}{dx} = \frac{1}{e^y(1+x^2)}$$

that satisfies the condition  $y(1) = 0$ .

Each worked example has a solution in two columns, as explained below.

### Solution

In this column the necessary steps are identified.

This differential equation is of first order and non-linear. *Separation of variables* is applicable because the right-hand side can be written as the product of a function of  $y$  and a function of  $x$ .

Divide through by the ‘function of  $y$ ’ on the right-hand side. Then everything involving  $y$  is on the left-hand side of the equation and everything involving  $x$  is on the right-hand side. (In this way, the *variables* have been *separated*.)

Now integrate both sides of the equation with respect to  $x$ , and apply the rule for integration by substitution on the left to reach an integral with respect to  $y$ .

Evaluate the integrals. (You may need to refer to the table of standard integrals given in the *Handbook*. Remember to add an arbitrary constant  $C$  when integrating the right-hand side.) This gives the *general solution* of the differential equation in *implicit form*.

Where possible, try to rearrange the solution to give  $y$  in terms of  $x$  (which is the *explicit form* of the general solution).

Now use the given condition,  $y(1) = 0$ , by putting  $x = 1$  and  $y = 0$  in the general solution. Hence find a value for the constant  $C$ .

Substituting the value of  $C$  back into the general solution gives the required *particular solution*. This satisfies *both* the differential equation *and* the condition  $y(1) = 0$ .

In this column the calculations are shown.

$$\frac{dy}{dx} = \frac{1}{e^y(1+x^2)} \quad \left( = \left( \frac{1}{e^y} \right) \times \left( \frac{1}{1+x^2} \right) \right)$$

$$e^y \frac{dy}{dx} = \frac{1}{1+x^2}$$

$$\int e^y \frac{dy}{dx} dx = \int \frac{1}{1+x^2} dx$$

$$\int e^y dy = \int \frac{1}{1+x^2} dx$$

$$e^y = \arctan x + C$$

$$y = \ln(\arctan x + C)$$

When  $x = 1$ ,  $y = 0$ , so  $0 = \ln(\arctan 1 + C)$ , that is,  $C = 1 - \arctan 1 = 1 - \frac{1}{4}\pi$ .

$$y = \ln \left( \arctan x + 1 - \frac{1}{4}\pi \right) \quad \blacksquare$$

### Comment

Any solution (general or particular) obtained from a differential equation can be checked by substituting it back into the differential equation. A particular solution can also be checked by substituting it into any additional (initial or boundary) conditions that it was intended to satisfy.

### Exercise 1.1

Obtain the general solution of the differential equation

$$\frac{dy}{dx} = \frac{e^x}{y}.$$

Find also the particular solution that satisfies the condition  $y(0) = 1$ .

#### Steps

- Is the differential equation of the type that can be solved by the separation of variables technique?
- Rearrange the equation so that all of the terms involving  $y$  are on the left-hand side and those involving  $x$  are on the right-hand side.
- Now integrate both sides and rearrange the solution to give  $y$  in terms of  $x$ . (This gives the *general solution*.)
- Put  $x = 0$  and  $y = 1$  to find the value of the arbitrary constant. Substitute this value into the general solution. (This gives the *particular solution*.)

Each worked example is followed by a structured exercise, like this.

The steps (questions or instructions) after the problem statement are designed to lead you to the solution of the problem. You can check your solutions against those at the back of the booklet.

### Exercise 1.2

Solve the following differential equations and, in each case, find the particular solution that satisfies the given condition.

(a)  $\frac{dp}{dz} = -\left(\frac{\rho_0 g}{p_0}\right)p, \quad p(0) = p_0, \quad \text{where } p_0, \rho_0 \text{ and } g \text{ are constants.}$

(b)  $\frac{dy}{dx} = \frac{xy}{x^2 + 1}, \quad y(0) = 5.$

(c)  $\frac{dy}{dx} = (y + 1) \sin x, \quad y\left(\frac{1}{2}\pi\right) = 0.$

(d)  $\frac{dp}{dz} = -\frac{gp}{R(\Theta_0 - kz)}, \quad p(0) = p_0,$

where  $R, g, \Theta_0, k$  and  $p_0$  are constants.

(e)  $y^2 \frac{dy}{dx} = \frac{1}{(x+2)(2-x)} \quad (-2 < x < 2), \quad y(0) = 3.$

(Hint:  $\frac{1}{(x+2)(2-x)} = \frac{1}{4} \left( \frac{1}{x+2} + \frac{1}{2-x} \right)$  for  $-2 < x < 2$ .)

Each structured exercise is followed by one or more further exercises, like this. Answers to these exercises are given at the back of the booklet.

## 1.2 Integrating factor method

### Example 1.2

Find the particular solution of the differential equation

$$x \frac{dy}{dx} = x^2 + 2y \quad (x > 0)$$

that satisfies the condition  $y(1) = 2$ .

### Solution

This differential equation is of first order, but the variables cannot be separated. It can be solved using the *integrating factor method*, because it can be written in the form

$$\frac{dy}{dx} + g(x)y = h(x),$$

where  $g(x)$  and  $h(x)$  are given functions. This is a *linear* differential equation.

Divide through by  $x$ , so that the coefficient of  $dy/dx$  is 1, and bring the  $y$  term to the left-hand side. The equation can then be seen to be of the required form.

Identify the two functions  $g(x)$  and  $h(x)$ .

The *integrating factor*,  $p(x)$ , is defined by

$$p(x) = \exp\left(\int g(x) dx\right).$$

Multiply the differential equation through by  $p(x)$ . It can then be written in the form

$$\frac{d}{dx}[p(x)y] = h(x)p(x), \quad \text{so that}$$

$$p(x)y = \int h(x)p(x) dx.$$

Evaluate the integral on the right-hand side, to obtain the *implicit form* of the general solution.

Rearrange to obtain  $y$  in terms of  $x$ , that is, the *explicit form* of the general solution.

Now use the given condition  $y(1) = 2$  to find the value of  $C$ .

This value gives the required particular solution, which satisfies the differential equation and the condition  $y(1) = 2$ .

$$x \frac{dy}{dx} = x^2 + 2y$$

$$\frac{dy}{dx} - \frac{2}{x}y = x$$

$$g(x) = -2/x, \quad h(x) = x.$$

$$\begin{aligned} p(x) &= \exp\left(\int \left(-\frac{2}{x}\right) dx\right) = \exp(-2 \ln x) \\ &= \exp(\ln(x^{-2})) = x^{-2} \end{aligned}$$

$$\frac{1}{x^2} \frac{dy}{dx} - \frac{2}{x^3}y = \frac{1}{x}$$

$$\frac{d}{dx}\left(\frac{1}{x^2}y\right) = \frac{1}{x}$$

$$\frac{1}{x^2}y = \int \frac{1}{x} dx$$

$$\frac{1}{x^2}y = \ln x + C$$

$$y = x^2(\ln x + C) \quad (x > 0)$$

When  $x = 1$ ,  $y = 2$ , so  $2 = C$ .

$$y = x^2(2 + \ln x) \quad \blacksquare$$

### Comment

No constant of integration is needed in the expression for the integrating factor,  $p(x)$ . Once  $p(x)$  has been found, it is good practice to check that

$$\frac{d}{dx}[p(x)y] = p(x)\frac{dy}{dx} + p(x)g(x)y.$$

### Exercise 1.3

Obtain the general solution of the differential equation

$$\frac{dy}{dx} = x + y.$$

Find also the particular solution that satisfies the condition  $y(0) = 1$ .

#### Steps

- Is the differential equation linear? If so, what are  $g(x)$  and  $h(x)$ ?
- Find the integrating factor,  $p(x)$ , for this problem.
- Multiply the differential equation through by  $p(x)$ , and write the left-hand side as a derivative. Integrate both sides, then rearrange the solution to give  $y$  in terms of  $x$ . (This gives the general solution.)
- Put  $x = 0$  and  $y = 1$  to give a value for the arbitrary constant. Substitute this value into the general solution. (This gives the particular solution.)

### Exercise 1.4

Solve the following differential equations, and find in each case the particular solution that satisfies the given condition.

- $x \frac{dy}{dx} = x^3 - 3y$  ( $x > 0$ ),  $y(1) = 1$ .
- $\frac{dy}{dx} = \sin x + y \tan x$  ( $-\frac{1}{2}\pi < x < \frac{1}{2}\pi$ ),  $y(0) = \frac{1}{2}$ .
- $\frac{dy}{dx} - \lambda y = e^{\lambda x}$ ,  $y(0) = 2$ , where  $\lambda$  is a constant.
- $(2x + 1) \frac{dy}{dx} = x - 2y$  ( $x > -\frac{1}{2}$ ),  $y(2) = 0$ .
- $\frac{dy}{dx} = y + x^2$ ,  $y(1) = 5$ .

## 1.3 Which method to use?

The above two methods of solving first-order differential equations can be used only for certain types of equation. One of the first steps in solving a problem involving a first-order differential equation is to decide whether either method is suitable. The following exercise enables you to revise this important first step. There is no need to solve the equations.

### Exercise 1.5

Which of the following equations may be solved by

- A separation of variables;  
B the integrating factor method;  
C neither of the above methods?

- |                               |                                    |                                    |
|-------------------------------|------------------------------------|------------------------------------|
| (a) $\frac{dy}{dx} = x$       | (b) $\frac{dy}{dx} = y$            | (c) $\frac{dy}{dx} = xy$           |
| (d) $\frac{dy}{dx} = x - y$   | (e) $\frac{dy}{dx} = y^2$          | (f) $\frac{dy}{dx} = x + y^2$      |
| (g) $\frac{dy}{dx} = x^2 + y$ | (h) $\frac{dy}{dx} = \sqrt{1 + y}$ | (i) $\frac{dy}{dx} = \sqrt{x + y}$ |

## 1.4 Second-order equations

### Example 1.3

Find the particular solution of the differential equation

$$\frac{d^2y}{dx^2} - 2\frac{dy}{dx} + 5y = 2x + 3$$

that satisfies the conditions  $y(0) = \frac{4}{5}$  and  $\frac{dy}{dx}(0) = 1$ .

### Solution

The differential equation is of second order, because the order of the highest derivative is 2. It is linear, because the coefficients of  $y$ ,  $dy/dx$  and  $d^2y/dx^2$  are not functions of  $y$  or its derivatives. It is *inhomogeneous*, since there are non-zero terms that do not involve  $y$  or its derivatives. The coefficients of  $y$  and its derivatives are constants, namely,  $a = 1$ ,  $b = -2$  and  $c = 5$ .

For linear inhomogeneous second-order differential equations, the general solution is the sum of the complementary function and a particular integral. First find the *complementary function*, which is the general solution of the associated *homogeneous* equation

$$a\frac{d^2y}{dx^2} + b\frac{dy}{dx} + cy = 0. \quad (1)$$

A solution of this constant-coefficient equation is of the form  $e^{\lambda x}$ . Substitution of  $e^{\lambda x}$  into each term of Equation (1) gives a quadratic equation in  $\lambda$  known as the *auxiliary equation*,

$$a\lambda^2 + b\lambda + c = 0, \quad (2)$$

which needs to be solved for  $\lambda$ .

(i) If Equation (2) has two real roots,  $\lambda_1$  and  $\lambda_2$ , then the general solution of Equation (1) is

$$y(x) = Ae^{\lambda_1 x} + Be^{\lambda_2 x},$$

where  $A$  and  $B$  are arbitrary constants.

(ii) If Equation (2) has only one real root,  $\lambda_1$  (since  $a\lambda^2 + b\lambda + c$  is a perfect square), then the general solution of Equation (1) is

$$y(x) = (A + Bx)e^{\lambda_1 x}.$$

(iii) If Equation (2) has complex conjugate roots,  $\lambda = \alpha + i\beta$  and  $\lambda = \alpha - i\beta$ , then the general solution of Equation (1) is

$$y(x) = e^{\alpha x}(A \cos(\beta x) + B \sin(\beta x)).$$

Here we have case (iii), with  $\alpha = 1$  and  $\beta = 2$ . (Second-order equations have two arbitrary constants in the general solution, here  $A$  and  $B$ .)

The given (inhomogeneous) differential equation is

$$\frac{d^2y}{dx^2} - 2\frac{dy}{dx} + 5y = 2x + 3.$$

The associated homogeneous equation is

$$\frac{d^2y}{dx^2} - 2\frac{dy}{dx} + 5y = 0.$$

The auxiliary equation is

$$\begin{aligned} \lambda^2 - 2\lambda + 5 &= 0, & \text{so} \\ \lambda &= \frac{2 \pm \sqrt{4 - 20}}{2} = \frac{2 \pm 4i}{2} = 1 \pm 2i. \end{aligned}$$

The complementary function is

$$y_c = e^x(A \cos(2x) + B \sin(2x)).$$

A *particular integral* is any function that satisfies the given inhomogeneous differential equation. The following table shows the usual form of the particular integral, given as a trial (test) function, for some of the different functions  $f(x)$  which may appear on the right-hand side of the inhomogeneous differential equation.

$f(x)$	Trial function, $y_p$
$m$ (constant)	$p$ (constant)
$m_1x + m_0$	$p_1x + p_0$
$me^{kx}$	$pe^{kx}$
$m \cos(\Omega x) + n \sin(\Omega x)$	$p \cos(\Omega x) + q \sin(\Omega x)$

Here there is a linear function of  $x$  on the right-hand side, so seek  $p_1$  and  $p_0$  such that  $y_p = p_1x + p_0$  satisfies the differential equation.

Substitute for  $y_p$ ,  $dy_p/dx$  and  $d^2y_p/dx^2$  in the differential equation, to obtain two equations for  $p_1$  and  $p_0$ . The solutions for  $p_1$  and  $p_0$  give the particular integral for this problem.

The sum of the complementary function and the particular integral is the general solution of the original differential equation.

Now use the two given conditions,  $y(0) = \frac{4}{5}$  and  $(dy/dx)(0) = 1$ , to find values for the constants  $A$  and  $B$ . For the second condition, the derivative of the general solution is needed.

Substituting the values of  $A$  and  $B$  back into the general solution gives the required particular solution. This satisfies the differential equation and the two given conditions.

The given inhomogeneous equation is

$$\frac{d^2y}{dx^2} - 2\frac{dy}{dx} + 5y = 2x + 3.$$

Try  $y_p = p_1x + p_0$ .

Then  $\frac{dy_p}{dx} = p_1$  and  $\frac{d^2y_p}{dx^2} = 0$ , so

$$0 - 2p_1 + 5(p_1x + p_0) = 2x + 3,$$

that is,

$$5p_1x + (5p_0 - 2p_1) = 2x + 3.$$

Comparing coefficients gives

$$\begin{aligned} 5p_1 &= 2 & \text{and} & & 5p_0 - 2p_1 &= 3, & \text{so} \\ p_1 &= \frac{2}{5} & \text{and} & & p_0 &= \frac{19}{25}. \end{aligned}$$

The particular integral is

$$y_p = \frac{2}{5}x + \frac{19}{25}.$$

The general solution is  $y = y_c + y_p$ , that is,

$$y = e^x(A \cos(2x) + B \sin(2x)) + \frac{2}{5}x + \frac{19}{25}.$$

When  $x = 0$ ,  $y = \frac{4}{5}$ , so  $\frac{4}{5} = A + \frac{19}{25}$ , and  $A = \frac{1}{25}$ . The derivative of the general solution is (using the Product Rule)

$$\frac{dy}{dx} = e^x((A + 2B) \cos(2x) + (B - 2A) \sin(2x)) + \frac{2}{5}.$$

When  $x = 0$ ,  $dy/dx = 1$ , so

$$1 = A + 2B + \frac{2}{5} = 2B + \frac{11}{25} \quad \text{and} \quad B = \frac{7}{25}.$$

The particular solution is

$$y = e^x \left( \frac{1}{25} \cos(2x) + \frac{7}{25} \sin(2x) \right) + \frac{2}{5}x + \frac{19}{25}. \quad \blacksquare$$

---

### Comment

Exceptionally, the 'trial function' does not work if the function to be tried contains a term that is a solution of the associated homogeneous equation (1). In this case, multiply the trial function by  $x$  (and if that still does not work, multiply the original trial function by  $x^2$ ).

Note that the complementary function,  $y_c$ , should be found before the particular integral,  $y_p$ . The additional conditions (at  $x = 0$  in Example 1.3) should be applied to the general solution,  $y = y_c + y_p$ , and not to  $y_c$  alone.

### Exercise 1.6

Find the particular solution of the differential equation

$$\frac{d^2y}{dx^2} + 2\frac{dy}{dx} - 3y = e^{2x}$$

that satisfies the conditions  $y(0) = \frac{1}{5}$  and  $\frac{dy}{dx}(0) = 0$ .

#### Steps

- Is the differential equation linear, with constant coefficients and of second order? What is the associated homogeneous equation?
- Write down and solve the auxiliary equation. Hence find the complementary function.
- Use a 'trial function' to find a particular integral that satisfies the given inhomogeneous differential equation.
- Add the particular integral to the complementary function, to obtain the general solution.
- Put  $x = 0$ ,  $y = \frac{1}{5}$  and  $x = 0$ ,  $dy/dx = 0$  in turn, to find a value for each of the unknown constants in the general solution. This gives the required particular solution.

### Exercise 1.7

Solve the following differential equations and, in each case, find the particular solution for which  $y = 0$  and  $dy/dx = 1$  when  $x = 0$ .

(a)  $5\frac{d^2y}{dx^2} - 6\frac{dy}{dx} + y = 21e^{-4x}$

(b)  $5\frac{d^2y}{dx^2} - 6\frac{dy}{dx} + y = e^{x/5}$

(c)  $4\frac{d^2y}{dx^2} + y = \sin x$

(d)  $\frac{d^2y}{dx^2} - 2\frac{dy}{dx} + y = 5x - 2$

(e)  $\frac{d^2y}{dx^2} + \frac{dy}{dx} + y = \cos(3x) - 2\sin(3x)$

### Exercise 1.8

Find the general solution of the differential equation

$$\frac{d^2y}{dx^2} + 16y = \cos(4x) - 8e^{3x}.$$

Find also the particular solution for which  $y = 0$ ,  $dy/dx = 0$  when  $x = 0$ .

---

## 2 Functions of more than one variable

### 2.1 Partial differentiation

#### Example 2.1

Find the second-order partial derivatives of the function

$$u(x, y) = \cos(4x + 3y),$$

and confirm that  $\frac{\partial^2 u}{\partial x \partial y} = \frac{\partial^2 u}{\partial y \partial x}$  (or equivalently,  $u_{xy} = u_{yx}$ ).

Partial derivatives may be denoted using subscripts, with  $u_x$  for  $\partial u/\partial x$ ,  $u_{xy}$  for  $\partial^2 u/\partial x \partial y$ , etc.

#### Solution

The first step is to calculate the first-order partial derivatives,  $\partial u/\partial x$  (i.e.  $u_x$ ) and  $\partial u/\partial y$  (i.e.  $u_y$ ).

The first of these,  $\partial u/\partial x$ , is calculated by differentiating  $u$  with respect to  $x$  while holding  $y$  constant. In other words,  $y$  is treated as if it were a constant.

Now, to find  $\partial u/\partial y$ , differentiate  $u$  with respect to  $y$  while holding  $x$  constant. This time,  $x$  is treated as a constant.

The second-order partial derivatives are  $\partial^2 u/\partial x^2$  (i.e.  $u_{xx}$ ),  $\partial^2 u/\partial x \partial y$  (i.e.  $u_{xy}$ ),  $\partial^2 u/\partial y^2$  (i.e.  $u_{yy}$ ) and  $\partial^2 u/\partial y \partial x$  (i.e.  $u_{yx}$ ). Here  $\partial^2 u/\partial x^2$  is obtained by differentiating  $\partial u/\partial x$  partially with respect to  $x$  (treating  $y$  as a constant.)

Now  $\partial^2 u/\partial x \partial y$  is obtained by differentiating  $\partial u/\partial y$  partially with respect to  $x$  (keeping  $y$  constant).

For  $\partial^2 u/\partial y^2$ , differentiate  $\partial u/\partial y$  partially with respect to  $y$  (keeping  $x$  constant).

Finally, obtain  $\partial^2 u/\partial y \partial x$  by differentiating  $\partial u/\partial x$  partially with respect to  $y$  (keeping  $x$  constant).

This property of mixed second-order partial derivatives is valid for all functions that will be met in the course.

$$u(x, y) = \cos(4x + 3y)$$

$$\begin{aligned}\frac{\partial u}{\partial x} &= -\sin(4x + 3y) \times 4 \\ &= -4\sin(4x + 3y)\end{aligned}$$

$$\begin{aligned}\frac{\partial u}{\partial y} &= -\sin(4x + 3y) \times 3 \\ &= -3\sin(4x + 3y)\end{aligned}$$

$$\begin{aligned}\frac{\partial^2 u}{\partial x^2} &= \frac{\partial}{\partial x}(-4\sin(4x + 3y)) \\ &= -4\cos(4x + 3y) \times 4 \\ &= -16\cos(4x + 3y)\end{aligned}$$

$$\begin{aligned}\frac{\partial^2 u}{\partial x \partial y} &= \frac{\partial}{\partial x}(-3\sin(4x + 3y)) \\ &= -3\cos(4x + 3y) \times 4 \\ &= -12\cos(4x + 3y)\end{aligned}$$

$$\begin{aligned}\frac{\partial^2 u}{\partial y^2} &= \frac{\partial}{\partial y}(-3\sin(4x + 3y)) \\ &= -3\cos(4x + 3y) \times 3 \\ &= -9\cos(4x + 3y)\end{aligned}$$

$$\begin{aligned}\frac{\partial^2 u}{\partial y \partial x} &= \frac{\partial}{\partial y}(-4\sin(4x + 3y)) \\ &= -4\cos(4x + 3y) \times 3 \\ &= -12\cos(4x + 3y)\end{aligned}$$

Comparison with  $\partial^2 u/\partial x \partial y$  confirms that

$$\frac{\partial^2 u}{\partial x \partial y} = \frac{\partial^2 u}{\partial y \partial x}. \quad \blacksquare$$

### Exercise 2.1

Find the second-order partial derivatives of the function

$$u(x, y) = A \cos(ax) e^{-a^2 y}, \quad \text{where } a \text{ and } A \text{ are constants,}$$

and confirm that  $\frac{\partial^2 u}{\partial x \partial y} = \frac{\partial^2 u}{\partial y \partial x}$ .

#### Steps

- (a) Differentiate  $u$  partially with respect to  $x$  (treating  $y$  as if it were a constant) to find  $\partial u / \partial x$ . Now differentiate  $u$  partially with respect to  $y$  (treating  $x$  as if it were a constant) to find  $\partial u / \partial y$ .
- (b) Keeping  $y$  constant, differentiate  $\partial u / \partial x$  with respect to  $x$ , to find  $\partial^2 u / \partial x^2$ .

Keeping  $y$  constant, differentiate  $\partial u / \partial y$  with respect to  $x$ , to find  $\partial^2 u / \partial x \partial y$ .

Keeping  $x$  constant, differentiate  $\partial u / \partial y$  with respect to  $y$ , to find  $\partial^2 u / \partial y^2$ .

Keeping  $x$  constant, differentiate  $\partial u / \partial x$  with respect to  $y$ , to find  $\partial^2 u / \partial y \partial x$ . Confirm that  $\partial^2 u / \partial x \partial y = \partial^2 u / \partial y \partial x$ .

### Exercise 2.2

Find the second-order partial derivatives of the following functions.

- (a)  $u(x, y) = \sin(x - y)$   
(b)  $u(r, \theta) = r \ln \theta \quad (\theta > 0)$   
(c)  $u(s, t) = \sin(st)$

### Exercise 2.3

- (a) Find the first-order partial derivatives  $\partial u / \partial x$  and  $\partial u / \partial t$  for

$$u(x, y, z, t) = (x^2 + y^2 + z^2) e^{-4t}.$$

- (b) Find also the second-order partial derivatives  $\partial^2 u / \partial x \partial y$  and  $\partial^2 u / \partial z \partial t$ .

## 2.2 Taylor polynomials

### Example 2.2

The form of the second-order Taylor polynomial  $p_2(x, y)$  for a function of two variables  $u(x, y)$  about the point  $(a, b)$  is

$$p_2(x, y) = u(a, b) + (x - a) \frac{\partial u}{\partial x}(a, b) + (y - b) \frac{\partial u}{\partial y}(a, b) + \frac{1}{2}(x - a)^2 \frac{\partial^2 u}{\partial x^2}(a, b) \\ + (x - a)(y - b) \frac{\partial^2 u}{\partial x \partial y}(a, b) + \frac{1}{2}(y - b)^2 \frac{\partial^2 u}{\partial y^2}(a, b).$$

Find the second-order Taylor polynomial for the function

$$u(x, y) = \cos(4x + 3y)$$

about the point  $(\frac{1}{8}\pi, \frac{1}{6}\pi)$ .

The first- and second-order partial derivatives for this function were obtained in Example 2.1.

### Solution

---

The necessary partial derivatives were obtained previously; now the function and its derivatives need to be evaluated at  $(\frac{1}{8}\pi, \frac{1}{6}\pi)$ .

First evaluate at  $(\frac{1}{8}\pi, \frac{1}{6}\pi)$  the function

$$u(x, y) = \cos(4x + 3y).$$

$$u\left(\frac{1}{8}\pi, \frac{1}{6}\pi\right) = \cos\left(4 \times \frac{1}{8}\pi + 3 \times \frac{1}{6}\pi\right) = \cos \pi = -1$$

Now evaluate at  $(\frac{1}{8}\pi, \frac{1}{6}\pi)$  the first-order partial derivatives

$$\frac{\partial u}{\partial x}(x, y) = -4 \sin(4x + 3y),$$

$$\frac{\partial u}{\partial x}\left(\frac{1}{8}\pi, \frac{1}{6}\pi\right) = -4 \sin \pi = 0$$

$$\frac{\partial u}{\partial y}(x, y) = -3 \sin(4x + 3y).$$

$$\frac{\partial u}{\partial y}\left(\frac{1}{8}\pi, \frac{1}{6}\pi\right) = -3 \sin \pi = 0$$

Evaluate the second-order partial derivatives

$$\frac{\partial^2 u}{\partial x^2}(x, y) = -16 \cos(4x + 3y),$$

$$\frac{\partial^2 u}{\partial x^2}\left(\frac{1}{8}\pi, \frac{1}{6}\pi\right) = -16 \cos \pi = 16$$

$$\frac{\partial^2 u}{\partial x \partial y}(x, y) = -12 \cos(4x + 3y),$$

$$\frac{\partial^2 u}{\partial x \partial y}\left(\frac{1}{8}\pi, \frac{1}{6}\pi\right) = -12 \cos \pi = 12$$

$$\frac{\partial^2 u}{\partial y^2}(x, y) = -9 \cos(4x + 3y).$$

$$\frac{\partial^2 u}{\partial y^2}\left(\frac{1}{8}\pi, \frac{1}{6}\pi\right) = -9 \cos \pi = 9$$

Now substitute these values into the formula for  $p_2(x, y)$ .

The polynomial  $p_2(x, y)$  is

$$\begin{aligned} & -1 + 0\left(x - \frac{1}{8}\pi\right) + 0\left(y - \frac{1}{6}\pi\right) + \frac{1}{2} \times 16\left(x - \frac{1}{8}\pi\right)^2 \\ & \quad + 12\left(x - \frac{1}{8}\pi\right)\left(y - \frac{1}{6}\pi\right) + \frac{1}{2} \times 9\left(y - \frac{1}{6}\pi\right)^2 \\ & = -1 + 8\left(x - \frac{1}{8}\pi\right)^2 + 12\left(x - \frac{1}{8}\pi\right)\left(y - \frac{1}{6}\pi\right) \\ & \quad + \frac{9}{2}\left(y - \frac{1}{6}\pi\right)^2. \quad \blacksquare \end{aligned}$$

---

### Exercise 2.4

Find the second-order Taylor polynomial for the function  $u(x, y) = \sin(xy)$  about the point  $(0, \frac{1}{4}\pi)$ .

#### Steps

- Find  $u(0, \frac{1}{4}\pi)$ .
- Use the solution of Exercise 2.2(c) to find  $(\partial u / \partial x)(0, \frac{1}{4}\pi)$  and  $(\partial u / \partial y)(0, \frac{1}{4}\pi)$ .
- Referring to the same solution, calculate the second-order partial derivatives at  $(0, \frac{1}{4}\pi)$ .
- Substitute the values for the derivatives found above into the formula for the second-order Taylor polynomial, and simplify where possible.

This formula is given in the statement of Example 2.2.

### Exercise 2.5

Find the second-order Taylor polynomial for the function  $u(x, y) = e^x \cos y$  about the point  $(0, 0)$ .

---

## 2.3 The Chain Rule

### Example 2.3

Use the *Chain Rule*

$$\frac{du}{ds} = \frac{\partial u}{\partial x} \frac{dx}{ds} + \frac{\partial u}{\partial y} \frac{dy}{ds}$$

to find  $du/ds$ , where

$$u(x, y) = x^2 + \sqrt{y} \quad (y \geq 0) \quad \text{and} \quad x = 2s, \quad y = s^2.$$

### Solution

First work out all of the derivatives on the right-hand side of the Chain Rule.

$$\begin{aligned} \frac{\partial u}{\partial x} &= 2x; & \frac{dx}{ds} &= 2; \\ \frac{\partial u}{\partial y} &= \frac{1}{2}y^{-1/2}; & \frac{dy}{ds} &= 2s. \end{aligned}$$

Now substitute these derivatives into the formula.

$$\frac{du}{ds} = 2x \times 2 + \frac{1}{2}y^{-1/2} \times 2s = 4x + \frac{s}{\sqrt{y}}$$

Then substitute for  $x$  and  $y$  in terms of  $s$ .

$$\frac{du}{ds} = 4 \times 2s + \frac{s}{\sqrt{s^2}} = 8s + 1$$

Notice that substituting for  $x$  and  $y$  in the expression for  $u$ , and then differentiating with respect to  $s$ , leads to the same result.

$$\begin{aligned} u &= (2s)^2 + \sqrt{s^2} = 4s^2 + s, & \text{so} \\ \frac{du}{ds} &= 8s + 1. \quad \blacksquare \end{aligned}$$

### Exercise 2.6

Use the Chain Rule to find  $du/ds$ , where

$$u = x^2 + y^2 \quad \text{and} \quad x = \cos s, \quad y = \sin s.$$

#### Steps

- Find the derivatives  $\partial u/\partial x$ ,  $\partial u/\partial y$ ,  $dx/ds$ ,  $dy/ds$ .
- Substitute into the Chain Rule, as given in Example 2.3.
- Substitute for  $x$  and  $y$  in terms of  $s$ .

### Exercise 2.7

Use the Chain Rule to find  $du/ds$  in each of the following cases.

- $u(x, y) = x^2 - y^2$  and  $x = 2s$ ,  $y = 1 - 2s$ ;
- $u(x, y) = x^2y - xy^2$  and  $x = \cos s$ ,  $y = \sin s$ ;
- $u(x, y) = e^y \cos x$  and  $x = s^2$ ,  $y = s^3$ .

# 3 Vector algebra and calculus

## 3.1 Addition, scalar and vector products

### Example 3.1

For the vectors  $\mathbf{a} = 3\mathbf{i} + 2\mathbf{j} - 5\mathbf{k}$  and  $\mathbf{b} = 2\mathbf{i} - \mathbf{j} - \mathbf{k}$ , find  $\mathbf{a} + \mathbf{b}$ ,  $|\mathbf{a} + \mathbf{b}|$ ,  $\mathbf{a} \cdot \mathbf{b}$ ,  $\mathbf{a} \times \mathbf{b}$  and the cosine of the angle between  $\mathbf{a}$  and  $\mathbf{b}$ .

### Solution

To add two vectors, add the corresponding components. So if

$$\mathbf{a} = a_1\mathbf{i} + a_2\mathbf{j} + a_3\mathbf{k}, \quad \mathbf{b} = b_1\mathbf{i} + b_2\mathbf{j} + b_3\mathbf{k}, \quad \mathbf{a} = 3\mathbf{i} + 2\mathbf{j} - 5\mathbf{k}, \quad \mathbf{b} = 2\mathbf{i} - \mathbf{j} - \mathbf{k}$$

then

$$\begin{aligned} \mathbf{a} + \mathbf{b} &= (a_1 + b_1)\mathbf{i} + (a_2 + b_2)\mathbf{j} + (a_3 + b_3)\mathbf{k}. & \mathbf{a} + \mathbf{b} &= (3\mathbf{i} + 2\mathbf{j} - 5\mathbf{k}) + (2\mathbf{i} - \mathbf{j} - \mathbf{k}) \\ & & &= 5\mathbf{i} + \mathbf{j} - 6\mathbf{k} \end{aligned}$$

The *magnitude* or *length*  $|\mathbf{a}|$  of a vector  $\mathbf{a}$  is given in terms of its components by

$$\begin{aligned} |\mathbf{a}| &= \sqrt{a_1^2 + a_2^2 + a_3^2}. & |\mathbf{a} + \mathbf{b}| &= \sqrt{5^2 + 1^2 + (-6)^2} \\ & & &= \sqrt{25 + 1 + 36} = \sqrt{62} \end{aligned}$$

The *scalar (dot) product* of  $\mathbf{a}$  and  $\mathbf{b}$  is defined as

$$\mathbf{a} \cdot \mathbf{b} = |\mathbf{a}| |\mathbf{b}| \cos \theta,$$

where  $\theta$  is the angle between  $\mathbf{a}$  and  $\mathbf{b}$ . In component form,

$$\begin{aligned} \mathbf{a} \cdot \mathbf{b} &= a_1b_1 + a_2b_2 + a_3b_3. & \mathbf{a} \cdot \mathbf{b} &= 3 \times 2 + 2 \times (-1) + (-5) \times (-1) \\ & & &= 6 - 2 + 5 = 9 \end{aligned}$$

The *vector (cross) product* of  $\mathbf{a}$  and  $\mathbf{b}$  is defined as

$$\mathbf{a} \times \mathbf{b} = (|\mathbf{a}| |\mathbf{b}| \sin \theta) \hat{\mathbf{c}},$$

where  $\hat{\mathbf{c}}$  is a unit vector whose direction is perpendicular to both  $\mathbf{a}$  and  $\mathbf{b}$ , and whose sense is given by the right-hand screw rule. In component form,

$$\begin{aligned} \mathbf{a} \times \mathbf{b} &= (a_2b_3 - a_3b_2)\mathbf{i} + (a_3b_1 - a_1b_3)\mathbf{j} \\ &\quad + (a_1b_2 - a_2b_1)\mathbf{k}, & \mathbf{a} \times \mathbf{b} &= \begin{vmatrix} \mathbf{i} & \mathbf{j} & \mathbf{k} \\ 3 & 2 & -5 \\ 2 & -1 & -1 \end{vmatrix} \\ & & &= (2 \times (-1) - (-5) \times (-1))\mathbf{i} \\ & & &\quad - (3 \times (-1) - (-5) \times 2)\mathbf{j} \\ & & &\quad + (3 \times (-1) - 2 \times 2)\mathbf{k} \\ & & &= -7\mathbf{i} - 7\mathbf{j} - 7\mathbf{k} = -7(\mathbf{i} + \mathbf{j} + \mathbf{k}) \end{aligned}$$

or more conveniently, using determinant notation,

$$\mathbf{a} \times \mathbf{b} = \begin{vmatrix} \mathbf{i} & \mathbf{j} & \mathbf{k} \\ a_1 & a_2 & a_3 \\ b_1 & b_2 & b_3 \end{vmatrix}.$$

To find the cosine of the angle between  $\mathbf{a}$  and  $\mathbf{b}$ , first evaluate  $|\mathbf{a}|$  and  $|\mathbf{b}|$ .

$$\begin{aligned} |\mathbf{a}| &= \sqrt{3^2 + 2^2 + (-5)^2} = \sqrt{38} \\ |\mathbf{b}| &= \sqrt{2^2 + (-1)^2 + (-1)^2} = \sqrt{6} \end{aligned}$$

Then use the value of  $\mathbf{a} \cdot \mathbf{b}$ , found above, and the formula (from the definition of the dot product)

$$\cos \theta = \frac{\mathbf{a} \cdot \mathbf{b}}{|\mathbf{a}| |\mathbf{b}|}. \quad \cos \theta = \frac{9}{\sqrt{38}\sqrt{6}} = \frac{3}{2}\sqrt{\frac{3}{19}} \quad \blacksquare$$

### Comment

In handwritten work, all symbols for vectors should be underlined.

#### Exercise 3.1

For the vectors  $\mathbf{a} = 3\mathbf{i} - 2\mathbf{j} + \mathbf{k}$  and  $\mathbf{b} = \mathbf{i} - 3\mathbf{j} + 5\mathbf{k}$ , find  $\mathbf{a} + \mathbf{b}$ ,  $|\mathbf{a} + \mathbf{b}|$ ,  $\mathbf{a} \cdot \mathbf{b}$ ,  $\mathbf{a} \times \mathbf{b}$  and the cosine of the angle,  $\theta$ , between  $\mathbf{a}$  and  $\mathbf{b}$ .

#### Steps

- Find  $\mathbf{a} + \mathbf{b}$  by adding components.
- Now sum the squares of the components of  $\mathbf{a} + \mathbf{b}$  and take the square root, to find  $|\mathbf{a} + \mathbf{b}|$ .
- Use the fact that  $\mathbf{a} \cdot \mathbf{b} = a_1b_1 + a_2b_2 + a_3b_3$  to find  $\mathbf{a} \cdot \mathbf{b}$ .
- Use the result

$$\mathbf{a} \times \mathbf{b} = \begin{vmatrix} \mathbf{i} & \mathbf{j} & \mathbf{k} \\ a_1 & a_2 & a_3 \\ b_1 & b_2 & b_3 \end{vmatrix}$$

to find  $\mathbf{a} \times \mathbf{b}$ .

- Use the definition  $\mathbf{a} \cdot \mathbf{b} = |\mathbf{a}| |\mathbf{b}| \cos \theta$ , and the result of part (c), to find  $\cos \theta$ .

#### Exercise 3.2

In each of the following cases, find  $\mathbf{a} + \mathbf{b}$ ,  $|\mathbf{a} + \mathbf{b}|$ ,  $\mathbf{a} \cdot \mathbf{b}$ ,  $\mathbf{a} \times \mathbf{b}$  and the cosine of the angle,  $\theta$ , between  $\mathbf{a}$  and  $\mathbf{b}$ .

- $\mathbf{a} = 2\mathbf{i} - 3\mathbf{j} + \mathbf{k}$ ,  $\mathbf{b} = -\mathbf{i} + 2\mathbf{j} + 4\mathbf{k}$ .
- $\mathbf{a} = 2\mathbf{i} + 2\mathbf{j} + \mathbf{k}$ ,  $\mathbf{b} = 4\mathbf{i} + 4\mathbf{j} - 7\mathbf{k}$ .

#### Exercise 3.3

- If  $\mathbf{a} \cdot \mathbf{b} = 0$ , what can be said about the vectors  $\mathbf{a}$  and  $\mathbf{b}$ ?
- If  $\mathbf{a} \times \mathbf{b} = \mathbf{0}$ , what can be said about the vectors  $\mathbf{a}$  and  $\mathbf{b}$ ?
- Consider the two vectors  $\mathbf{a} = \mathbf{i} + 2\mathbf{j} + \mathbf{k}$  and  $\mathbf{b} = -\mathbf{i} + \mathbf{k}$ . Are these two vectors either parallel or perpendicular to each other?
- Find the value of  $(\mathbf{c} \times \mathbf{d}) \cdot \mathbf{c}$  for any non-zero vectors  $\mathbf{c}$  and  $\mathbf{d}$ .

#### Exercise 3.4

Consider the three vectors  $\mathbf{a} = a_1\mathbf{i} + a_2\mathbf{j} + a_3\mathbf{k}$ ,  $\mathbf{b} = b_1\mathbf{i} + b_2\mathbf{j} + b_3\mathbf{k}$  and  $\mathbf{c} = c_1\mathbf{i} + c_2\mathbf{j} + c_3\mathbf{k}$ .

- Evaluate the scalar triple product  $\mathbf{a} \cdot (\mathbf{b} \times \mathbf{c})$ , and show that this equals the determinant of the components of  $\mathbf{a}$ ,  $\mathbf{b}$  and  $\mathbf{c}$ , that is,

$$\begin{vmatrix} a_1 & a_2 & a_3 \\ b_1 & b_2 & b_3 \\ c_1 & c_2 & c_3 \end{vmatrix}.$$

- Hence, using the properties of determinants, verify that

$$\mathbf{a} \cdot (\mathbf{b} \times \mathbf{c}) = \mathbf{b} \cdot (\mathbf{c} \times \mathbf{a}) = \mathbf{c} \cdot (\mathbf{a} \times \mathbf{b}).$$

## 3.2 Position, velocity and acceleration

### Example 3.2

If  $\mathbf{r} = 2 \cos(3t) \mathbf{i} + 2 \sin(3t) \mathbf{j} + (2t - 1) \mathbf{k}$  is the position vector at time  $t$  of a moving particle, find

- the velocity of the particle;
- the speed of the particle;
- the acceleration of the particle;
- a unit vector in the direction of the tangent to the trajectory of the particle at  $\mathbf{r}$ .

Although the course does not specifically solve problems in particle mechanics, many of the basic ideas concerning the relationship between position, velocity and acceleration vectors do occur.

### Solution

(a) If the *position vector* of the particle at time  $t$  is  $\mathbf{r}(t)$ , then the *velocity vector*  $\mathbf{v}(t)$  is the derivative of  $\mathbf{r}$  with respect to  $t$ . Differentiate each component, since  $\mathbf{i}$ ,  $\mathbf{j}$  and  $\mathbf{k}$  are constant vectors.

$$\begin{aligned}\mathbf{r} &= 2 \cos(3t) \mathbf{i} + 2 \sin(3t) \mathbf{j} + (2t - 1) \mathbf{k} \\ \mathbf{v} &= \frac{d\mathbf{r}}{dt} = -6 \sin(3t) \mathbf{i} + 6 \cos(3t) \mathbf{j} + 2 \mathbf{k}\end{aligned}$$

(b) The *speed* of the particle is the magnitude of the velocity vector.

$$\begin{aligned}|\mathbf{v}| &= \sqrt{36 \sin^2(3t) + 36 \cos^2(3t) + 4} \\ &= \sqrt{40} = 2\sqrt{10} \quad (\text{since } \sin^2(3t) + \cos^2(3t) = 1)\end{aligned}$$

(c) The *acceleration vector*  $\mathbf{a}(t)$  is the derivative of the velocity vector with respect to  $t$ . This can also be written as the second derivative of  $\mathbf{r}$  with respect to  $t$ .

$$\mathbf{a} = \frac{d\mathbf{v}}{dt} = -18 \cos(3t) \mathbf{i} - 18 \sin(3t) \mathbf{j}$$

(d) The curve traced out by the particle as it moves (often called the *pathline*) is the geometrical representation of the vector function  $\mathbf{r}(t)$ . The derivative  $d\mathbf{r}/dt = \mathbf{v}$  at a point on the curve is a tangent vector to the curve at that point. A unit vector in the direction of this tangent vector is

From part (a),

$$\mathbf{v} = -6 \sin(3t) \mathbf{i} + 6 \cos(3t) \mathbf{j} + 2 \mathbf{k},$$

and from part (b),  $|\mathbf{v}| = 2\sqrt{10}$ .

Hence

$$\mathbf{e}_t = \frac{1}{\sqrt{10}}(-3 \sin(3t) \mathbf{i} + 3 \cos(3t) \mathbf{j} + \mathbf{k}). \quad \blacksquare$$

$$\mathbf{e}_t = \frac{d\mathbf{r}/dt}{|d\mathbf{r}/dt|} = \frac{\mathbf{v}}{|\mathbf{v}|}.$$

### Comment

In this course, we often use the geometrical interpretation of  $d\mathbf{r}/ds$  as a vector in the direction of the tangent to the curve traced out by the position vector,  $\mathbf{r}(s) = x(s) \mathbf{i} + y(s) \mathbf{j} + z(s) \mathbf{k}$ , as the parameter  $s$  varies. In Example 3.2, the parameter  $s$  equals  $t$ , and represents time.

### Exercise 3.5

The position of a moving particle at time  $t$  is described by the position vector  $\mathbf{r}(t) = \cos(mt)\hat{\mathbf{b}} + \sin(mt)\hat{\mathbf{c}}$ , where  $\hat{\mathbf{b}}$  and  $\hat{\mathbf{c}}$  are constant, perpendicular unit vectors, and  $m$  is a positive constant. Find the velocity and acceleration vectors of the particle when  $t = 0$ . Find also a unit vector in the direction of motion of the particle (that is, in the direction of the velocity vector).

Show that, at any point on the pathline, the velocity vector is perpendicular to the position vector.

#### Steps

- To find the velocity vector  $\mathbf{v}$ , evaluate the derivative of  $\mathbf{r}(t)$  with respect to  $t$ . Then put  $t = 0$  into your result.
- To find the acceleration vector  $\mathbf{a}$ , evaluate the derivative of  $\mathbf{v}(t)$  with respect to  $t$ . Then put  $t = 0$  into your result.
- Evaluate the unit vector  $\mathbf{e}_t = \mathbf{v}/|\mathbf{v}|$ .
- Show that  $\mathbf{v} \cdot \mathbf{r} = 0$ .

### Exercise 3.6

The position vector of a moving particle is

$$\mathbf{r} = 2t\mathbf{i} + \frac{1}{6}t^3\mathbf{j} - 2\mathbf{k}.$$

Find the velocity and acceleration vectors, and show that

$$4v^2 = 16 + a^4,$$

where  $v$  and  $a$  are the magnitudes of the velocity and acceleration, respectively.

### Exercise 3.7

In plane polar coordinates  $(r, \theta)$ , the unit vectors in the radial and transverse directions are given by

$$\mathbf{e}_r = \cos\theta\mathbf{i} + \sin\theta\mathbf{j} \quad \text{and} \quad \mathbf{e}_\theta = -\sin\theta\mathbf{i} + \cos\theta\mathbf{j},$$

respectively, where  $\mathbf{i}$  and  $\mathbf{j}$  are Cartesian unit vectors.

- If the position vector of a moving particle at time  $t$  is  $\mathbf{r} = r\mathbf{e}_r$ , find expressions for the velocity and acceleration vectors in terms of  $\mathbf{e}_r$  and  $\mathbf{e}_\theta$ .
- For a particle moving in a circle with constant speed, show that the acceleration vector is parallel to the position vector, and that the velocity vector is perpendicular to the position vector.

In this course, polar coordinates are denoted by  $(r, \theta)$ , rather than (as in MST209) by  $\langle r, \theta \rangle$ .

Derivatives with respect to time can be made more concise using the Newtonian (dot) notation, with  $\dot{r}$  for  $dr/dt$ ,  $\ddot{r}$  for  $d^2r/dt^2$ , etc.

### 3.3 Gradient of a scalar field

#### Example 3.3

For  $\phi(x, y, z) = x^2y + 2xz$ , find  $\mathbf{grad} \phi$  at the point  $(2, -2, 3)$ .

#### Solution

The *gradient* of a scalar field  $\phi(x, y, z)$  is defined as

$$\mathbf{grad} \phi = \frac{\partial \phi}{\partial x} \mathbf{i} + \frac{\partial \phi}{\partial y} \mathbf{j} + \frac{\partial \phi}{\partial z} \mathbf{k}.$$

First, work out the partial derivatives  $\partial\phi/\partial x$ ,  $\partial\phi/\partial y$  and  $\partial\phi/\partial z$ .

Then combine them to obtain  $\mathbf{grad} \phi$ .

To evaluate this at  $(2, -2, 3)$ , substitute in the values for  $x$ ,  $y$  and  $z$ .

The scalar field is  $\phi(x, y, z) = x^2y + 2xz$ .

$$\frac{\partial \phi}{\partial x} = 2xy + 2z, \quad \frac{\partial \phi}{\partial y} = x^2, \quad \frac{\partial \phi}{\partial z} = 2x.$$

$$\mathbf{grad} \phi = (2xy + 2z) \mathbf{i} + x^2 \mathbf{j} + 2x \mathbf{k}$$

At  $(2, -2, 3)$ ,

$$\begin{aligned} \mathbf{grad} \phi &= (2 \times 2 \times (-2) + 2 \times 3) \mathbf{i} + 2^2 \mathbf{j} + 2 \times 2 \mathbf{k} \\ &= -2 \mathbf{i} + 4 \mathbf{j} + 4 \mathbf{k}. \quad \blacksquare \end{aligned}$$

#### Exercise 3.8

For  $\phi(x, y, z) = 3x^2y - y^3z^2$ , find  $\mathbf{grad} \phi$  at the point  $(1, 2, -1)$ .

#### Steps

- Find the partial derivatives  $\partial\phi/\partial x$ ,  $\partial\phi/\partial y$  and  $\partial\phi/\partial z$ .
- Substitute them into the definition of  $\mathbf{grad} \phi$ .
- Substitute for  $x$ ,  $y$  and  $z$  at the point  $(1, 2, -1)$ .

#### Exercise 3.9

In each case, find  $\mathbf{grad} \phi$  at the point specified.

- $\phi(x, y, z) = 2xz^2 - 3xy - 4x$ ;  $(1, -1, 2)$ .
- $\phi(x, y, z) = x^2yz + 4xz^2$ ;  $(1, -2, -1)$ .

#### Exercise 3.10

For  $\phi = x^2yz + 4xz^2$  (as in Exercise 3.9(b)), find

- the maximum rate of change of  $\phi$  at the point  $(1, -2, -1)$ , and the direction in which this maximum occurs;
- the rate of change of  $\phi$  at the point  $(1, 0, 1)$  in the direction of the unit vector  $\mathbf{e} = \frac{1}{3}\sqrt{3}(\mathbf{i} + \mathbf{j} + \mathbf{k})$ ;
- the direction of a normal vector to the surface  $\phi = 18$  at the point  $(1, 1, 2)$ .

#### Exercise 3.11

(a) If  $u = x^2 + y^2 + z^2$ ,  $x = t^2$ ,  $y = t - 1$  and  $z = t^3$ , calculate each of the following, expressing your answers in terms of  $t$ .

(i)  $\frac{du}{dt}$     (ii)  $\mathbf{grad} u$     (iii)  $\frac{d\mathbf{r}}{dt}$ , where  $\mathbf{r} = x\mathbf{i} + y\mathbf{j} + z\mathbf{k}$ .

(b) Evaluate the scalar product of  $\mathbf{grad} u$  and  $d\mathbf{r}/dt$ , and compare the result with that for part (a)(i).

### 3.4 Divergence and curl of a vector field

#### Example 3.4

For  $\mathbf{F} = x^2y \mathbf{i} - 2xz \mathbf{j} + 2yz \mathbf{k}$ , find  $\text{div } \mathbf{F}$  and  $\text{curl } \mathbf{F}$  at the point  $(1, 2, -1)$ .

#### Solution

Use the expressions for  $\text{div } \mathbf{F}$  (the *divergence* of  $\mathbf{F}$ ) and for  $\text{curl } \mathbf{F}$  in terms of derivatives; that is, if

$$\mathbf{F} = F_1 \mathbf{i} + F_2 \mathbf{j} + F_3 \mathbf{k},$$

then

$$\text{div } \mathbf{F} = \frac{\partial F_1}{\partial x} + \frac{\partial F_2}{\partial y} + \frac{\partial F_3}{\partial z} \qquad \text{div } \mathbf{F} = 2xy - 0 + 2y = 2y(x + 1)$$

and

$$\begin{aligned} \text{curl } \mathbf{F} &= \begin{vmatrix} \mathbf{i} & \mathbf{j} & \mathbf{k} \\ \partial/\partial x & \partial/\partial y & \partial/\partial z \\ F_1 & F_2 & F_3 \end{vmatrix} & \text{curl } \mathbf{F} &= \begin{vmatrix} \mathbf{i} & \mathbf{j} & \mathbf{k} \\ \partial/\partial x & \partial/\partial y & \partial/\partial z \\ x^2y & -2xz & 2yz \end{vmatrix} \\ &= \left( \frac{\partial F_3}{\partial y} - \frac{\partial F_2}{\partial z} \right) \mathbf{i} - \left( \frac{\partial F_3}{\partial x} - \frac{\partial F_1}{\partial z} \right) \mathbf{j} & &= (2z + 2x) \mathbf{i} - 0 \mathbf{j} + (-2z - x^2) \mathbf{k} \\ &+ \left( \frac{\partial F_2}{\partial x} - \frac{\partial F_1}{\partial y} \right) \mathbf{k}. & &= 2(x + z) \mathbf{i} - (x^2 + 2z) \mathbf{k} \end{aligned}$$

Now substitute the values of  $x$ ,  $y$  and  $z$  at the point  $(1, 2, -1)$ .

At  $(1, 2, -1)$ ,

$$\text{div } \mathbf{F} = 2 \times 2(1 + 1) = 8 \quad \text{and}$$

$$\text{curl } \mathbf{F} = 2(1 - 1) \mathbf{i} - (1 - 2) \mathbf{k} = \mathbf{k}. \quad \blacksquare$$

#### Exercise 3.12

For  $\mathbf{F} = xz^3 \mathbf{i} - 2x^2yz \mathbf{j} + 2yz^4 \mathbf{k}$ , find  $\text{div } \mathbf{F}$  and  $\text{curl } \mathbf{F}$  at the point  $(1, 1, -1)$ .

#### Steps

- Find  $\partial F_1/\partial x$ ,  $\partial F_2/\partial y$  and  $\partial F_3/\partial z$ . Put these into the formula for  $\text{div } \mathbf{F}$  and substitute for  $x$ ,  $y$  and  $z$  at the point  $(1, 1, -1)$ .
- Write  $\text{curl } \mathbf{F}$  as a  $3 \times 3$  determinant.
- Expand the determinant about the first row, taking the appropriate derivatives.
- Substitute for  $x$ ,  $y$  and  $z$  at the point  $(1, 1, -1)$ .

#### Exercise 3.13

In each case, find  $\text{div } \mathbf{F}$  and  $\text{curl } \mathbf{F}$  at the point specified.

- $\mathbf{F} = 2yz \mathbf{i} - x^2y \mathbf{j} + xz^2 \mathbf{k}$ ;  $(1, 1, 1)$ .
- $\mathbf{F} = x^2 \mathbf{i} + yz \mathbf{j} - xy \mathbf{k}$ ;  $(2, -1, 0)$ .
- $\mathbf{F} = 3xyz^2 \mathbf{i} + 2xy^3 \mathbf{j} - x^2yz \mathbf{k}$ ;  $(-1, 1, 2)$ .

# 4 Integration of scalar and vector fields

## 4.1 Line integrals

### Example 4.1

Evaluate the scalar line integral  $\oint_C \mathbf{F} \cdot d\mathbf{r}$ , where  $\mathbf{F} = -y\mathbf{i} + x\mathbf{j}$  and the closed curve  $C$  is the ellipse  $x^2/a^2 + y^2/b^2 = 1$ .

### Solution

The first step is to *parametrise* the curve so that every point on it is given in terms of a parameter  $t$ .

Substitute for  $x$  and  $y$  in  $\mathbf{F}$  and the position vector  $\mathbf{r}$ , in terms of the parameter  $t$ . Then find  $d\mathbf{r}/dt$  and  $\mathbf{F} \cdot d\mathbf{r}/dt$ .

The ellipse  $x^2/a^2 + y^2/b^2 = 1$  can be parametrised by

$$x = a \cos t, \quad y = b \sin t, \quad \text{where } 0 \leq t \leq 2\pi.$$

$$\mathbf{F} = -y\mathbf{i} + x\mathbf{j} = -b \sin t \mathbf{i} + a \cos t \mathbf{j}$$

$$\mathbf{r} = x\mathbf{i} + y\mathbf{j} = a \cos t \mathbf{i} + b \sin t \mathbf{j}$$

$$\frac{d\mathbf{r}}{dt} = -a \sin t \mathbf{i} + b \cos t \mathbf{j}$$

$$\begin{aligned} \mathbf{F} \cdot \frac{d\mathbf{r}}{dt} &= (-b \sin t \mathbf{i} + a \cos t \mathbf{j}) \cdot (-a \sin t \mathbf{i} + b \cos t \mathbf{j}) \\ &= ab \sin^2 t + ab \cos^2 t = ab \end{aligned}$$

The *scalar line integral* is then given by

$$\int_C \mathbf{F} \cdot d\mathbf{r} = \int_{t_0}^{t_1} \mathbf{F} \cdot \frac{d\mathbf{r}}{dt} dt,$$

where  $t_0$  and  $t_1$  are the parameter values at the ends of the curve. Evaluate this integral over  $t$ .

$$\begin{aligned} \oint_C \mathbf{F} \cdot d\mathbf{r} &= \int_{t=0}^{t=2\pi} \mathbf{F} \cdot \frac{d\mathbf{r}}{dt} dt \\ &= \int_{t=0}^{t=2\pi} ab dt = 2\pi ab. \quad \blacksquare \end{aligned}$$

### Comment

The notation  $\oint_C$ , rather than  $\int_C$ , indicates that in this example the curve is closed. The limits chosen for  $t$  correspond to going once anticlockwise around the curve  $C$ , starting and finishing at the same point.

### Exercise 4.1

Evaluate the scalar line integral  $\oint_C \mathbf{F} \cdot d\mathbf{r}$ , where the closed curve  $C$  is the circle  $x^2 + y^2 = a^2$  and  $\mathbf{F} = y(2xy - 1)\mathbf{i} + x(2xy + 1)\mathbf{j}$ .

### Steps

- The curve along which the integral is to be evaluated is a circle, centre the origin and radius  $a$ . Write down equations for  $x$  and  $y$  which will be a parametrisation of the circle, in terms of a parameter  $t$ . What are the limits for the integration over  $t$ ?
- Write down  $\mathbf{F}$  and  $\mathbf{r}$  in terms of  $t$ , by substituting for  $x$  and  $y$ , and evaluate the scalar product  $\mathbf{F} \cdot d\mathbf{r}/dt$ .
- Evaluate the integral of  $\mathbf{F} \cdot d\mathbf{r}/dt$  over  $t$ , between the limits specified in part (a).

### Exercise 4.2

Evaluate the scalar line integral  $\int_C \mathbf{F} \cdot d\mathbf{r}$  for each of the following vector fields  $\mathbf{F}$  and curves  $C$ .

- (a)  $\mathbf{F} = (2x + y)\mathbf{i} - x\mathbf{j}$ , and  $C$  is the quarter-circle, centre the origin and radius 2, between  $(2, 0)$  and  $(0, 2)$ .
  - (b)  $\mathbf{F} = 3x^2\mathbf{i} + (yz + x)\mathbf{j} - xy\mathbf{k}$ , and  $C$  is the straight line between the points  $(1, 0, -1)$  and  $(2, 1, 3)$ , defined by the parametrisation  $x = t$ ,  $y = t - 1$ ,  $z = 4t - 5$  ( $1 \leq t \leq 2$ ).
  - (c)  $\mathbf{F} = \mathbf{grad} \phi$ , where  $\phi = x^2yz + yz^3$ , and  $C$  is the straight line between the points  $A (0, 0, 0)$  and  $B (1, 1, 1)$ . Check your answer by using the scalar field  $\phi$  directly.
-

## 4.2 Surface integrals

### Example 4.2

Evaluate the surface integral  $\int_S xy \, dA$ , where  $S$  is the region of the plane  $z = 0$  bounded by the curve  $y = x^2$  and by the line  $y = x$ .

### Solution

In Cartesian coordinates,

$$\int_S xy \, dA = \iint_S xy \, dx \, dy.$$

First draw a diagram showing the region of integration,  $S$ . Mark on the diagram the minimum value  $a$  and maximum value  $b$  of  $x$ , for points on the boundary. These values form the limits of the  $x$ -integration, provided that this is done after the  $y$ -integration.

Find the values of  $a$  and  $b$  by solving the pair of simultaneous equations

$$y = x^2, \quad y = x.$$

Now draw on the diagram a vertical strip showing the limits of the  $y$ -integration, which in this case are  $y = x^2$  (lower) and  $y = x$  (upper).

Write the surface integral as two successive single integrals, one over  $y$  (the inner integral) and one over  $x$  (the outer integral). Integrate the inner integral (over  $y$ , holding  $x$  constant). Putting in the limits gives a function of  $x$ ,  $g(x)$  say.

The evaluation of the surface integral is completed by integrating the function  $g(x)$  between the limits  $x = a$  and  $x = b$ .

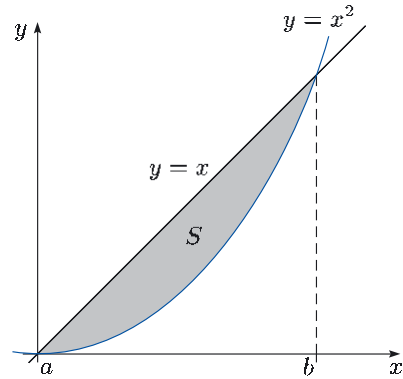

$$x^2 = x, \quad \text{so } x(x - 1) = 0, \quad \text{giving} \\ x = 0 \text{ or } x = 1 \text{ (that is, } a = 0 \text{ and } b = 1).$$

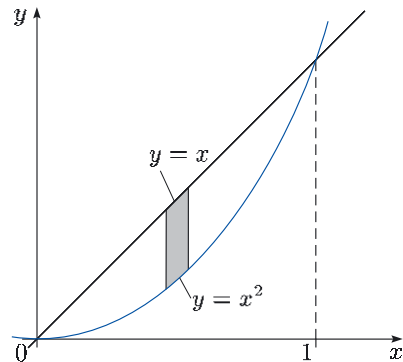

$$\int_S xy \, dA = \int_{x=0}^{x=1} \left( \int_{y=x^2}^{y=x} xy \, dy \right) dx \\ \int_{y=x^2}^{y=x} xy \, dy = x \left[ \frac{1}{2}y^2 \right]_{y=x^2}^{y=x} = x \left( \frac{1}{2}x^2 - \frac{1}{2}x^4 \right) \\ = \frac{1}{2}(x^3 - x^5) \quad (= g(x))$$

$$\int_{x=0}^{x=1} g(x) \, dx = \int_{x=0}^{x=1} \frac{1}{2}(x^3 - x^5) \, dx \\ = \frac{1}{2} \left[ \frac{1}{4}x^4 - \frac{1}{6}x^6 \right]_0^1 = \frac{1}{2} \left( \frac{1}{4} - \frac{1}{6} \right) = \frac{1}{24}. \quad \blacksquare$$

### Comment

The order of integrations in Example 4.2 is not the only possibility. By drawing in a horizontal strip, parallel to the  $x$ -axis, the surface integral can be written as

$$\int_S xy \, dA = \int_{y=0}^{y=1} \left( \int_{x=y}^{x=\sqrt{y}} xy \, dx \right) dy,$$

and integration then gives the same result as before.

### Exercise 4.3

Evaluate the surface integral  $\int_S (x^2 + y^2) \, dA$ , where  $S$  is the triangle in the plane  $z = 0$  formed by the lines  $y = 0$ ,  $y = x - 1$  and  $x = 2$ .

#### Steps

- Draw a diagram showing the region of integration,  $S$ .
- Mark on the diagram the minimum value  $a$  and maximum value  $b$  of  $x$ , for points on the boundary.
- Draw on the diagram a strip parallel to the  $y$ -axis, and show the lower and upper limits for the  $y$ -integration.
- Write the surface integral as two successive single integrals.
- Evaluate the inner integral (over  $y$ , holding  $x$  constant).
- Complete the evaluation of the surface integral by evaluating the outer integral from  $x = a$  to  $x = b$ .

### Exercise 4.4

Evaluate the surface integral  $\int_S f(x, y) \, dA$  for each of the following functions  $f$  and regions of integration  $S$ .

- $f(x, y) = p_0 + \rho_0 g(h_0 + x)$ , and  $S$  is the rectangle defined by  $0 \leq x \leq a$ ,  $0 \leq y \leq b$  (where  $p_0$ ,  $\rho_0$ ,  $g$  and  $h_0$  are constants).
- $f(x, y) = x - y$ , and  $S$  is the region bounded by the curves  $y = x^2$  and  $y = 4x - x^2$ .

### Exercise 4.5

This question is about the vector field  $\mathbf{F} = y\mathbf{i} + x^2y\mathbf{j}$  and the circle  $C$  with centre the origin and radius 2.

- Evaluate the scalar line integral  $\oint_C \mathbf{F} \cdot d\mathbf{r}$ .
- Evaluate the surface integral  $\int_S (\mathbf{curl} \mathbf{F}) \cdot \mathbf{k} \, dA$ , where  $S$  is the interior of the circle  $C$ , that is, the region  $x^2 + y^2 \leq 4$ . Compare your result with the answer to part (a).

## 4.3 Volume integrals

### Example 4.3

Evaluate the volume integral  $\int_B 3x^2yz \, dV$ , where  $B$  is the interior of the wedge-shaped region with faces in the planes  $x = 0$ ,  $y = 0$ ,  $z = 0$ ,  $x = 1$  and  $y + z = 1$ .

## Solution

In Cartesian coordinates,

$$\int_B f(x, y, z) dV = \int \int \int_B f(x, y, z) dx dy dz.$$

First draw two diagrams showing

(a) the region of integration,  $B$ ;

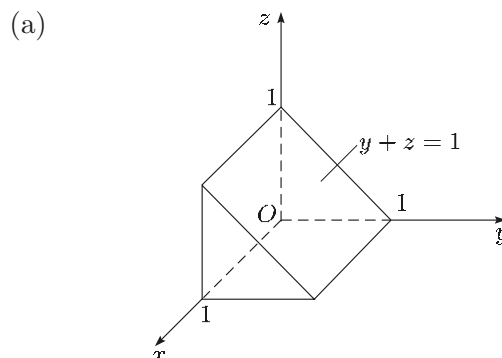

(b) the projection  $S$  of  $B$  onto the  $(x, y)$ -plane.

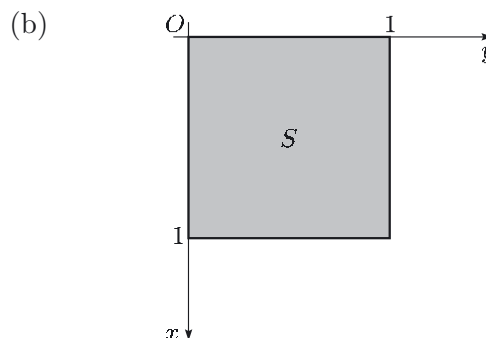

Now draw, within the region  $B$ , a vertical column of rectangular cross-section. The intersections of this column with the top and bottom faces of the region  $B$  give the limits of the  $z$ -integration, which in this case are  $z = 0$  (lower) and  $z = 1 - y$  (upper).

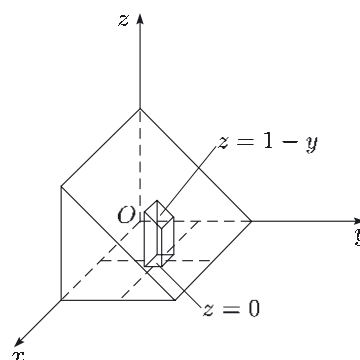

Evaluate the integral of  $f(x, y, z)$  over  $z$  between these limits.

$$\begin{aligned} \int_{z=0}^{z=1-y} 3x^2 y z dz &= 3x^2 y \left[ \frac{1}{2} z^2 \right]_{z=0}^{z=1-y} \\ &= \frac{3}{2} x^2 y (1-y)^2 \end{aligned}$$

The volume integral is now reduced to a surface integral over the projection of the region  $B$  onto the  $(x, y)$ -plane, that is, over the square  $S$  ( $0 \leq x \leq 1$ ,  $0 \leq y \leq 1$ ). The evaluation of this surface integral is completed using the steps of Subsection 4.2. (Other orders of integration are possible.)

$$\begin{aligned} \int_B 3x^2 y z dV &= \frac{3}{2} \int_S x^2 y (1-y)^2 dA \\ &= \frac{3}{2} \int_{x=0}^{x=1} x^2 \left( \int_{y=0}^{y=1} (y - 2y^2 + y^3) dy \right) dx \\ &= \frac{3}{2} \int_{x=0}^{x=1} x^2 \left[ \frac{1}{2} y^2 - \frac{2}{3} y^3 + \frac{1}{4} y^4 \right]_{y=0}^{y=1} dx \\ &= \frac{1}{8} \int_{x=0}^{x=1} x^2 dx = \frac{1}{24} \quad \blacksquare \end{aligned}$$

### Exercise 4.6

Evaluate the volume integral  $\int_B xz \, dV$ , where  $B$  is the region inside the semi-circular cylinder  $x^2 + y^2 = 1$ ,  $x \geq 0$ , and lying between the planes  $z = 0$  and  $z = 1$ .

#### Steps

- (a) Draw two diagrams showing
  - (i) the region of integration,  $B$ ;
  - (ii) the projection  $S$  of  $B$  onto the  $(x, y)$ -plane.
- (b) Draw on the region  $B$  a vertical column of rectangular cross-section parallel to the  $z$ -axis, and mark on this the upper and lower limits for the  $z$ -integration.
- (c) Evaluate the single integral of  $xz$  over  $z$  between these limits, to obtain a function  $g(x, y)$ , say.
- (d) Evaluate the surface integral of  $g(x, y)$  over the region  $S$  of part (a)(ii).

Other orders of integration are possible.

Alternatively, this volume integral could be evaluated using cylindrical polar coordinates, as shown in *Unit 4*.

### Exercise 4.7

Evaluate the volume integral  $\int_B f(x, y, z) \, dV$  for each of the following functions  $f$  and regions of integration  $B$ .

- (a)  $f(x, y, z) = x + y + z$ , and  $B$  is the interior of the cube with faces  $x = 0$ ,  $x = 1$ ,  $y = 0$ ,  $y = 1$ ,  $z = 0$  and  $z = 1$ .
- (b)  $f(x, y, z) = z + 3x - 2$ , and  $B$  is the region inside the prism with triangular cross-section  $y = 0$ ,  $y = x$ ,  $x = 2$  and lying between the planes  $z = 0$  and  $z = 1$ .

## 5 Dimensions

### 5.1 Dimensional consistency

#### Example 5.1

In terms of the *base dimensions* M of mass, L of length and T of time, give the dimensions of each of the following quantities:

area, speed, force.

The viscosity,  $\mu$ , of a fluid is defined by means of an experiment in which the fluid lies between two parallel plates, each of area  $A$  and separated by a small distance  $h$ . The upper plate moves with constant speed  $U$  when a constant shear force of magnitude  $F$  is applied to it, and it is found that

$$\frac{F}{A} = \mu \frac{U}{h}.$$

Use this result to find the dimensions of viscosity.

Recall that force is measured in newtons (N), where

$$1 \text{ N} = 1 \text{ kg m s}^{-2}.$$

## Solution

The notation  $[X]$  is used to mean ‘the dimensions of  $X$ ’. By definition,

$$\begin{aligned}[\text{mass}] &= M, \\ [\text{length}] &= L, \\ [\text{time}] &= T.\end{aligned}$$

*Dimensional consistency* requires that the dimensions on either side of a physically meaningful equation should be the same.

Since area is length times length,

$$[\text{area}] = L^2.$$

Since speed is distance (a length) divided by time,

$$[\text{speed}] = L T^{-1}.$$

Since force has the units of mass times length divided by time squared,

$$[\text{force}] = M L T^{-2}.$$

Rearranging the given equation,

$$\mu = \frac{Fh}{AU}.$$

From above,  $[F] = M L T^{-2}$ ,  $[A] = L^2$  and  $[U] = L T^{-1}$ , while  $[h] = L$ . Hence

$$[\mu] = \frac{[F][h]}{[A][U]} = \frac{(M L T^{-2})(L)}{(L^2)(L T^{-1})} = M L^{-1} T^{-1}. \quad \blacksquare$$

### Exercise 5.1

In terms of  $M$ ,  $L$  and  $T$ , give the dimensions of each of the following quantities:

pressure (force per unit area), density (mass per unit volume).

The equation of state for a gas is

$$p = R\rho\Theta,$$

where  $p$  is the gas pressure,  $\rho$  is its density,  $\Theta$  is its absolute temperature and  $R$  is the gas constant. Find the dimensions of  $R$  in terms of  $M$ ,  $L$ ,  $T$  and  $\Theta$  (the base dimension of temperature).

#### Steps

- Use the dimensions of force, area (both from Example 5.1) and volume to deduce those of pressure and density.
- Express  $R$  in terms of  $p$ ,  $\rho$  and  $\Theta$ . Then use the dimensions of these quantities and dimensional consistency to deduce the dimensions of  $R$ .

### Exercise 5.2

Give the dimensions of each of the following quantities:

acceleration, kinetic energy.

### Exercise 5.3

The magnitude  $F$  of the gravitational force between two spheres of masses  $m_1$  and  $m_2$  is given by

$$F = \frac{Gm_1m_2}{r^2},$$

where  $r$  is the distance between the two spheres and  $G$  is the universal gravitational constant. Find the dimensions of  $G$ .

## 5.2 Dimensional analysis

### Example 5.2

Assume that the range  $R$  (distance from launch to landing) of a projectile, launched from ground level, depends on the mass  $m$ , launch speed  $u$  and launch angle  $\theta$  of the projectile, and on the magnitude  $g$  of the acceleration due to gravity, that is,  $R = f(m, u, \theta, g)$ . Use dimensional analysis to find a possible form for the function  $f$ .

Recall that angle is a dimensionless quantity, so  $[\theta] = 1$ .

### Solution

First note the dimensions of the given variables.

Assume that the dependent variable is a product of powers of the independent variables, and apply dimensional consistency to write a corresponding equation in terms of dimensions.

Translate into base dimensions, then equate the powers of M, L and T on either side of the equation.

Solve the resulting equations for the powers of the independent variables. Any undetermined power, such as  $\gamma$  here, leads to an undetermined function in the final result. (In fact, the analysis here shows that  $Rg/u^2$  is a *dimensionless group* of variables. Since  $\theta$  is also dimensionless, it is expected that  $Rg/u^2 = h(\theta)$  for some function  $h$ .)

We have  $[R] = L$ ,  $[m] = M$ ,  $[u] = L T^{-1}$ ,  $[\theta] = 1$  and  $[g] = L T^{-2}$ .

Assume that  $R = k m^\alpha u^\beta \theta^\gamma g^\delta$ , where  $k$  is a dimensionless constant. Then

$$[R] = [m]^\alpha [u]^\beta [\theta]^\gamma [g]^\delta.$$

Using the dimensions above, we have

$$\begin{aligned} L &= M^\alpha (L T^{-1})^\beta (L T^{-2})^\delta \\ &= M^\alpha L^{\beta+\delta} T^{-\beta-2\delta}. \end{aligned}$$

Equating powers of M, L and T in turn gives

$$M: 0 = \alpha, \quad L: 1 = \beta + \delta, \quad T: 0 = -\beta - 2\delta,$$

with solution

$$\alpha = 0, \quad \beta = 2, \quad \delta = -1.$$

Hence  $R = k u^2 \theta^\gamma g^{-1}$ , where  $\gamma$  is undetermined.

We deduce that

$$R = h(\theta) \frac{u^2}{g},$$

where  $h$  is an undetermined function. ■

### Exercise 5.4

Use dimensional analysis to find a possible expression for the magnitude  $F$  of the drag force acting on a sphere moving through a fluid, assuming that it depends only on the speed  $v$  and radius  $r$  of the sphere, and on the density  $\rho$  and viscosity  $\mu$  of the fluid.

#### Steps

- Note the dimensions of the given variables.
- Expressing  $F$  as a product  $k v^\alpha r^\beta \rho^\gamma \mu^\delta$ , use dimensional consistency to relate the dimensions of the variables.
- Translate into base dimensions (using step (a)), then equate the powers of M, L and T on either side of the equation.
- Solve the resulting equations for  $\alpha$ ,  $\beta$ ,  $\gamma$ ,  $\delta$ , by expressing  $\beta$ ,  $\gamma$ ,  $\delta$  in terms of  $\alpha$ .
- Rearrange the resulting equation for  $F$ , from step (b), so that the undetermined power  $\alpha$  appears just once. (The resulting quantity which is raised to the power  $\alpha$  is a dimensionless group.)
- Finally, replace the factor that involves  $\alpha$  by an undetermined function of the dimensionless group.

From Example 5.1 and Exercise 5.1,

$$[F] = \text{MLT}^{-2},$$

$$[\rho] = \text{ML}^{-3},$$

$$[\mu] = \text{ML}^{-1}\text{T}^{-1}.$$

### Exercise 5.5

Use dimensional analysis to find a possible expression for the period  $\tau$  of a pendulum, assuming that it depends only on the mass  $m$  of the bob, the length  $l$  of the stem, the angular amplitude  $\Phi$  of the oscillations and the magnitude  $g$  of the acceleration due to gravity.

---

# Solutions to the exercises

## Section 1

### Solution 1.1

(a) The differential equation is of first order, and the right-hand side can be written as  $(e^x) \times (1/y)$ .

(b)  $y \frac{dy}{dx} = e^x$

(c)  $\int y dy = \int e^x dx$ , so  
 $\frac{1}{2}y^2 = e^x + C$ , leading to  
 $y = \pm \sqrt{2(e^x + C)}$  ( $e^x + C > 0$ ).

(d) Putting  $x = 0$  and  $y = 1$ , we have

$$1 = \pm \sqrt{2(e^0 + C)},$$

giving  $C = -\frac{1}{2}$  (after the necessary choice of the positive square root). So the particular solution satisfying the condition  $y(0) = 1$  is

$$y = \sqrt{2e^x - 1} \quad (2e^x - 1 > 0, \text{ or } x > -\ln 2).$$

### Solution 1.2

In each case, the general solution is followed by the particular solution. Both  $A$  and  $C$  are arbitrary constants.

- (a)  $p = Ae^{-\rho_0 gz/p_0}$ ;  $p = p_0 e^{-\rho_0 gz/p_0}$ .
- (b)  $y = \exp\left(\frac{1}{2} \ln(x^2 + 1) + C\right) = A\sqrt{x^2 + 1}$ ;  
 $y = 5\sqrt{x^2 + 1}$ .
- (c)  $y = \exp(C - \cos x) - 1 = Ae^{-\cos x} - 1$ ;  
 $y = e^{-\cos x} - 1$ .
- (d)  $p = \exp\left(\frac{g}{Rk} \ln(\Theta_0 - kz) + C\right)$   
 $= A(\Theta_0 - kz)^{g/(Rk)}$ ;  $p = p_0 \left(\frac{\Theta_0 - kz}{\Theta_0}\right)^{g/(Rk)}$ .
- (e)  $y = \left(\frac{3}{4} \ln\left(\frac{2+x}{2-x}\right) + C\right)^{1/3}$ ;  
 $y = \left(\frac{3}{4} \ln\left(\frac{2+x}{2-x}\right) + 27\right)^{1/3}$ .

### Solution 1.3

(a) The equation is linear. It is equivalent to

$$\frac{dy}{dx} - y = x,$$

so  $g(x) = -1$  and  $h(x) = x$ .

(b)  $p(x) = \exp\left(\int g(x) dx\right) = \exp\left(\int (-1) dx\right) = e^{-x}$

(c)  $\frac{d}{dx}(e^{-x}y) = xe^{-x}$ , so  
 $e^{-x}y = \int xe^{-x} dx$ .

Integrating the right-hand side by parts, we have

$$\int xe^{-x} dx = -xe^{-x} - \int 1(-e^{-x}) dx$$

$$= -xe^{-x} - e^{-x} + C, \quad \text{so that}$$

$$e^{-x}y = -(x+1)e^{-x} + C.$$

With  $y$  in terms of  $x$ , the general solution is

$$y = Ce^x - (x+1).$$

(d) Putting  $x = 0$  and  $y = 1$ , we have

$$1 = C - 1, \quad \text{giving } C = 2,$$

so the particular solution for the given condition is

$$y = 2e^x - (x+1).$$

### Solution 1.4

In each case, the general solution is followed by the particular solution, and  $C$  is an arbitrary constant.

- (a)  $y = \frac{1}{6}x^3 + \frac{C}{x^3}$ ;  $y = \frac{1}{6}x^3 + \frac{5}{6x^3}$ .
- (b)  $y = C \sec x - \frac{1}{2} \cos x$ ;  $y = \sec x - \frac{1}{2} \cos x$ .
- (c)  $y = (x+C)e^{\lambda x}$ ;  $y = (x+2)e^{\lambda x}$ .
- (d)  $y = \frac{x^2 + 2C}{2(1+2x)}$ ;  $y = \frac{x^2 - 4}{2(1+2x)}$ .
- (e)  $y = Ce^x - (x^2 + 2x + 2)$ ;  
 $y = 10e^{x-1} - (x^2 + 2x + 2)$ .

### Solution 1.5

- (a) A or B (or direct integration)  
 (b) A or B    (c) A or B    (d) B    (e) A  
 (f) C    (g) B    (h) A    (i) C

### Solution 1.6

(a) The equation is linear, with constant coefficients and of second order. The homogeneous equation is

$$\frac{d^2y}{dx^2} + 2\frac{dy}{dx} - 3y = 0.$$

(b) The auxiliary equation is  $\lambda^2 + 2\lambda - 3 = 0$ .

Solving for  $\lambda$ , we have

$$\lambda = \frac{-2 \pm \sqrt{4+12}}{2} = -1 \pm 2,$$

that is,  $\lambda = 1$  or  $\lambda = -3$ .

The complementary function is

$$y_c = Ae^x + Be^{-3x}.$$

(c) In this problem,  $f(x) = e^{2x}$ , so the trial function is  $y_p = pe^{2x}$ . Substituting into the differential equation, we obtain

$$4pe^{2x} + 2(2pe^{2x}) - 3pe^{2x} = e^{2x}, \quad \text{so that}$$

$$5pe^{2x} = e^{2x} \quad \text{or} \quad p = \frac{1}{5}.$$

The particular integral is  $y_p = \frac{1}{5}e^{2x}$ .

(d) The general solution is  $y = Ae^x + Be^{-3x} + \frac{1}{5}e^{2x}$ .

(e) The condition  $y(0) = \frac{1}{5}$  gives

$$A + B + \frac{1}{5} = \frac{1}{5} \quad \text{or} \quad A + B = 0,$$

and the condition  $(dy/dx)(0) = 0$  gives

$$A - 3B + \frac{2}{5} = 0.$$

Solving for  $A$  and  $B$  gives  $A = -\frac{1}{10}$  and  $B = \frac{1}{10}$ . The particular solution satisfying the given conditions is

$$y = -\frac{1}{10}e^x + \frac{1}{10}e^{-3x} + \frac{1}{5}e^{2x}.$$

### Solution 1.7

In each case, the form of the trial function is followed by the general solution and then by the particular solution. Both  $A$  and  $B$  are arbitrary constants.

(a)  $y_p = p e^{-4x}$ ;  $y = Ae^x + Be^{x/5} + \frac{1}{5}e^{-4x}$ ;

$$y = \frac{23}{10}e^x - \frac{5}{2}e^{x/5} + \frac{1}{5}e^{-4x}.$$

(b)  $y_p = px e^{x/5}$ ;  $y = Ae^x + Be^{x/5} - \frac{1}{4}x e^{x/5}$ ;

$$y = \frac{25}{16}(e^x - e^{x/5}) - \frac{1}{4}x e^{x/5}.$$

(c)  $y_p = p \cos x + q \sin x$ ;

$$y = A \cos\left(\frac{1}{2}x\right) + B \sin\left(\frac{1}{2}x\right) - \frac{1}{3} \sin x;$$

$$y = \frac{8}{3} \sin\left(\frac{1}{2}x\right) - \frac{1}{3} \sin x.$$

(d)  $y_p = p_1 x + p_0$ ;  $y = (A + Bx)e^x + 5x + 8$ ;

$$y = (4x - 8)e^x + 5x + 8.$$

(e)  $y_p = p \cos(3x) + q \sin(3x)$ ;

$$y = e^{-x/2} \left( A \cos\left(\frac{1}{2}\sqrt{3}x\right) + B \sin\left(\frac{1}{2}\sqrt{3}x\right) \right)$$

$$- \frac{2}{73} \cos(3x) + \frac{19}{73} \sin(3x);$$

$$y = e^{-x/2} \left( \frac{2}{73} \cos\left(\frac{1}{2}\sqrt{3}x\right) + \frac{34}{219}\sqrt{3} \sin\left(\frac{1}{2}\sqrt{3}x\right) \right)$$

$$- \frac{2}{73} \cos(3x) + \frac{19}{73} \sin(3x).$$

### Solution 1.8

Trial function is

$$y_p = x(p \cos(4x) + q \sin(4x)) + re^{3x}.$$

General solution is

$$y = A \cos(4x) + B \sin(4x) + \frac{1}{8}x \sin(4x) - \frac{8}{25}e^{3x}.$$

Particular solution is

$$y = \frac{8}{25} \cos(4x) + \frac{6}{25} \sin(4x) + \frac{1}{8}x \sin(4x) - \frac{8}{25}e^{3x}.$$

## Section 2

### Solution 2.1

(a) When  $y$  is treated as a constant,  $e^{-a^2 y}$  is constant, so

$$\frac{\partial u}{\partial x} = -Aa \sin(ax) e^{-a^2 y}.$$

When  $x$  is treated as a constant,  $\cos(ax)$  is constant, so

$$\frac{\partial u}{\partial y} = -Aa^2 \cos(ax) e^{-a^2 y}.$$

$$(b) \frac{\partial^2 u}{\partial x^2} = \frac{\partial}{\partial x}(-Aa \sin(ax) e^{-a^2 y})$$

$$= -Aa^2 \cos(ax) e^{-a^2 y};$$

$$\frac{\partial^2 u}{\partial x \partial y} = \frac{\partial}{\partial x}(-Aa^2 \cos(ax) e^{-a^2 y})$$

$$= Aa^3 \sin(ax) e^{-a^2 y};$$

$$\frac{\partial^2 u}{\partial y^2} = \frac{\partial}{\partial y}(-Aa^2 \cos(ax) e^{-a^2 y})$$

$$= Aa^4 \cos(ax) e^{-a^2 y};$$

$$\frac{\partial^2 u}{\partial y \partial x} = \frac{\partial}{\partial y}(-Aa \sin(ax) e^{-a^2 y})$$

$$= Aa^3 \sin(ax) e^{-a^2 y} \quad \left( = \frac{\partial^2 u}{\partial x \partial y} \right).$$

### Solution 2.2

$$(a) \frac{\partial u}{\partial x} = \cos(x - y); \quad \frac{\partial u}{\partial y} = -\cos(x - y);$$

$$\frac{\partial^2 u}{\partial x^2} = -\sin(x - y), \quad \frac{\partial^2 u}{\partial y^2} = -\sin(x - y);$$

$$\frac{\partial^2 u}{\partial x \partial y} = \frac{\partial^2 u}{\partial y \partial x} = \sin(x - y).$$

$$(b) \frac{\partial u}{\partial r} = \ln \theta; \quad \frac{\partial u}{\partial \theta} = \frac{r}{\theta}; \quad \frac{\partial^2 u}{\partial r^2} = 0;$$

$$\frac{\partial^2 u}{\partial \theta^2} = -\frac{r}{\theta^2}; \quad \frac{\partial^2 u}{\partial r \partial \theta} = \frac{\partial^2 u}{\partial \theta \partial r} = \frac{1}{\theta}.$$

$$(c) \frac{\partial u}{\partial s} = t \cos(st); \quad \frac{\partial u}{\partial t} = s \cos(st);$$

$$\frac{\partial^2 u}{\partial s^2} = -t^2 \sin(st); \quad \frac{\partial^2 u}{\partial t^2} = -s^2 \sin(st);$$

$$\frac{\partial^2 u}{\partial s \partial t} = \frac{\partial^2 u}{\partial t \partial s} = \cos(st) - st \sin(st).$$

### Solution 2.3

$$(a) \frac{\partial u}{\partial x} = 2x e^{-4t}; \quad \frac{\partial u}{\partial t} = -4(x^2 + y^2 + z^2) e^{-4t}.$$

$$(b) \frac{\partial^2 u}{\partial x \partial y} = 0; \quad \frac{\partial^2 u}{\partial z \partial t} = -8z e^{-4t}.$$

### Solution 2.4

$$(a) u(0, \frac{1}{4}\pi) = \sin(0 \times \frac{1}{4}\pi) = \sin 0 = 0$$

(b) In Solution 2.2(c), replace  $s, t$  by  $x, y$ , respectively.

$$\frac{\partial u}{\partial x}(0, \frac{1}{4}\pi) = \frac{1}{4}\pi \cos(0 \times \frac{1}{4}\pi) = \frac{1}{4}\pi;$$

$$\frac{\partial u}{\partial y}(0, \frac{1}{4}\pi) = 0 \cos(0 \times \frac{1}{4}\pi) = 0.$$

$$(c) \frac{\partial^2 u}{\partial x^2}(0, \frac{1}{4}\pi) = -\left(\frac{1}{4}\pi\right)^2 \sin(0 \times \frac{1}{4}\pi) = 0;$$

$$\frac{\partial^2 u}{\partial x \partial y}(0, \frac{1}{4}\pi) = \cos(0 \times \frac{1}{4}\pi) - 0 \times \frac{1}{4}\pi \sin(0 \times \frac{1}{4}\pi) = 1;$$

$$\frac{\partial^2 u}{\partial y^2}(0, \frac{1}{4}\pi) = -0^2 \sin(0 \times \frac{1}{4}\pi) = 0.$$

- (d) The second-order Taylor polynomial is
- $$p_2(x, y) = 0 + \frac{1}{4}\pi(x-0) + 0\left(y - \frac{1}{4}\pi\right) + \frac{1}{2} \times 0(x-0)^2 + 1(x-0)\left(y - \frac{1}{4}\pi\right) + \frac{1}{2} \times 0\left(y - \frac{1}{4}\pi\right)^2 = \frac{1}{4}\pi x + x\left(y - \frac{1}{4}\pi\right) = xy.$$

### Solution 2.5

The second-order Taylor polynomial is

$$p_2(x, y) = 1 + x + \frac{1}{2}x^2 - \frac{1}{2}y^2.$$

### Solution 2.6

$$(a) \quad \frac{\partial u}{\partial x} = 2x; \quad \frac{dx}{ds} = -\sin s;$$

$$\frac{\partial u}{\partial y} = 2y; \quad \frac{dy}{ds} = \cos s.$$

$$(b) \quad \frac{du}{ds} = 2x(-\sin s) + 2y(\cos s)$$

$$(c) \quad \frac{du}{ds} = -2\cos s \sin s + 2\sin s \cos s = 0$$

### Solution 2.7

$$(a) \quad \frac{du}{ds} = 4$$

$$(b) \quad \frac{du}{ds} = -2\cos s \sin^2 s + \sin^3 s + \cos^3 s - 2\cos^2 s \sin s$$

(This can also be written as

$$(\cos s + \sin s)(1 - 3\cos s \sin s).)$$

$$(c) \quad \frac{du}{ds} = e^{s^3}(-2s \sin(s^2) + 3s^2 \cos(s^2))$$

## Section 3

### Solution 3.1

$$(a) \quad \mathbf{a} + \mathbf{b} = (3\mathbf{i} - 2\mathbf{j} + \mathbf{k}) + (\mathbf{i} - 3\mathbf{j} + 5\mathbf{k}) = 4\mathbf{i} - 5\mathbf{j} + 6\mathbf{k}$$

$$(b) \quad |\mathbf{a} + \mathbf{b}| = \sqrt{4^2 + (-5)^2 + 6^2} = \sqrt{77}$$

$$(c) \quad \mathbf{a} \cdot \mathbf{b} = 3 \times 1 + (-2) \times (-3) + 1 \times 5 = 3 + 6 + 5 = 14$$

$$(d) \quad \mathbf{a} \times \mathbf{b} = \begin{vmatrix} \mathbf{i} & \mathbf{j} & \mathbf{k} \\ 3 & -2 & 1 \\ 1 & -3 & 5 \end{vmatrix} = (-2 \times 5 - 1 \times (-3))\mathbf{i} - (3 \times 5 - 1 \times 1)\mathbf{j} + (3 \times (-3) - (-2) \times 1)\mathbf{k} = -7\mathbf{i} - 14\mathbf{j} - 7\mathbf{k}$$

$$(e) \quad |\mathbf{a}| = \sqrt{3^2 + (-2)^2 + 1^2} = \sqrt{14}$$

$$|\mathbf{b}| = \sqrt{1^2 + (-3)^2 + 5^2} = \sqrt{35}$$

Hence  $14 = \sqrt{14}\sqrt{35} \cos \theta$ , and so

$$\cos \theta = \frac{14}{\sqrt{14}\sqrt{35}} = \sqrt{\frac{2}{5}}.$$

### Solution 3.2

$$(a) \quad \mathbf{a} + \mathbf{b} = \mathbf{i} - \mathbf{j} + 5\mathbf{k}; \quad |\mathbf{a} + \mathbf{b}| = \sqrt{27} = 3\sqrt{3};$$

$$\mathbf{a} \cdot \mathbf{b} = -4; \quad \mathbf{a} \times \mathbf{b} = -14\mathbf{i} - 9\mathbf{j} + \mathbf{k};$$

$$\cos \theta = -\frac{4}{\sqrt{14}\sqrt{21}} = -\frac{2}{21}\sqrt{6}.$$

$$(b) \quad \mathbf{a} + \mathbf{b} = 6\mathbf{i} + 6\mathbf{j} - 6\mathbf{k}; \quad |\mathbf{a} + \mathbf{b}| = \sqrt{108} = 6\sqrt{3};$$

$$\mathbf{a} \cdot \mathbf{b} = 9; \quad \mathbf{a} \times \mathbf{b} = -18\mathbf{i} + 18\mathbf{j}; \quad \cos \theta = \frac{1}{3}.$$

### Solution 3.3

(a) If  $\mathbf{a} \cdot \mathbf{b} = 0$ , then either  $\mathbf{a} = \mathbf{0}$  or  $\mathbf{b} = \mathbf{0}$  or  $\mathbf{a}$  and  $\mathbf{b}$  are perpendicular.

(b) If  $\mathbf{a} \times \mathbf{b} = \mathbf{0}$  then  $\mathbf{a} = \mathbf{0}$  or  $\mathbf{b} = \mathbf{0}$  or  $\mathbf{a}$  and  $\mathbf{b}$  are parallel (in the same or opposite directions).

(c) We have  $\mathbf{a} \cdot \mathbf{b} = 0$  and  $\mathbf{a} \times \mathbf{b} = 2\mathbf{i} - 2\mathbf{j} + 2\mathbf{k}$ . Since  $\mathbf{a} \neq \mathbf{0}$  and  $\mathbf{b} \neq \mathbf{0}$ ,  $\mathbf{a}$  and  $\mathbf{b}$  are perpendicular.

(d)  $(\mathbf{c} \times \mathbf{d}) \cdot \mathbf{c} = 0$  for any non-zero vectors  $\mathbf{c}$  and  $\mathbf{d}$ , because  $\mathbf{c} \times \mathbf{d}$  is perpendicular to  $\mathbf{c}$  and the dot product of perpendicular vectors is zero.

### Solution 3.4

$$(a) \quad \mathbf{b} \times \mathbf{c} = (b_2c_3 - b_3c_2)\mathbf{i} - (b_1c_3 - b_3c_1)\mathbf{j} + (b_1c_2 - b_2c_1)\mathbf{k}$$

$$\mathbf{a} \cdot (\mathbf{b} \times \mathbf{c}) = a_1(b_2c_3 - b_3c_2) - a_2(b_1c_3 - b_3c_1) + a_3(b_1c_2 - b_2c_1)$$

$$= \begin{vmatrix} a_1 & a_2 & a_3 \\ b_1 & b_2 & b_3 \\ c_1 & c_2 & c_3 \end{vmatrix}.$$

(b) Interchanging two rows of a determinant changes its sign, so

$$\mathbf{a} \cdot (\mathbf{b} \times \mathbf{c}) = \begin{vmatrix} a_1 & a_2 & a_3 \\ b_1 & b_2 & b_3 \\ c_1 & c_2 & c_3 \end{vmatrix} = - \begin{vmatrix} b_1 & b_2 & b_3 \\ a_1 & a_2 & a_3 \\ c_1 & c_2 & c_3 \end{vmatrix}$$

$$= \begin{vmatrix} b_1 & b_2 & b_3 \\ c_1 & c_2 & c_3 \\ a_1 & a_2 & a_3 \end{vmatrix} = \mathbf{b} \cdot (\mathbf{c} \times \mathbf{a}).$$

Similarly,  $\mathbf{a} \cdot (\mathbf{b} \times \mathbf{c}) = \mathbf{c} \cdot (\mathbf{a} \times \mathbf{b})$ .

### Solution 3.5

$$(a) \quad \mathbf{r} = \cos(mt)\widehat{\mathbf{b}} + \sin(mt)\widehat{\mathbf{c}}$$

$$\mathbf{v} = \frac{d\mathbf{r}}{dt} = -m \sin(mt)\widehat{\mathbf{b}} + m \cos(mt)\widehat{\mathbf{c}},$$

since  $d\widehat{\mathbf{b}}/dt = \mathbf{0}$  and  $d\widehat{\mathbf{c}}/dt = \mathbf{0}$ .

When  $t = 0$ , we have  $\mathbf{v} = -0\widehat{\mathbf{b}} + m\widehat{\mathbf{c}} = m\widehat{\mathbf{c}}$ .

$$(b) \quad \mathbf{a} = \frac{d\mathbf{v}}{dt} = -m^2 \cos(mt)\widehat{\mathbf{b}} - m^2 \sin(mt)\widehat{\mathbf{c}}$$

When  $t = 0$ , we have  $\mathbf{a} = -m^2\widehat{\mathbf{b}} - 0\widehat{\mathbf{c}} = -m^2\widehat{\mathbf{b}}$ .

(c) Since  $|\mathbf{v}| = m$ , we have

$$\mathbf{e}_t = \frac{\mathbf{v}}{|\mathbf{v}|} = -\sin(mt)\widehat{\mathbf{b}} + \cos(mt)\widehat{\mathbf{c}}.$$

(d) Since  $\widehat{\mathbf{b}} \cdot \widehat{\mathbf{c}} = 0$ ,  $\widehat{\mathbf{b}} \cdot \widehat{\mathbf{b}} = 1$  and  $\widehat{\mathbf{c}} \cdot \widehat{\mathbf{c}} = 1$  ( $\widehat{\mathbf{b}}$  and  $\widehat{\mathbf{c}}$  are perpendicular unit vectors), we have

$$\mathbf{v} \cdot \mathbf{r} = (-m \sin(mt)\widehat{\mathbf{b}} + m \cos(mt)\widehat{\mathbf{c}}) \cdot (\cos(mt)\widehat{\mathbf{b}} + \sin(mt)\widehat{\mathbf{c}}) = 0.$$

Hence  $\mathbf{v}$  and  $\mathbf{r}$  are perpendicular.

### Solution 3.6

$$(a) \mathbf{r} = 2t\mathbf{i} + \frac{1}{6}t^3\mathbf{j} - 2\mathbf{k}$$

$$\mathbf{v} = \frac{d\mathbf{r}}{dt} = 2\mathbf{i} + \frac{1}{2}t^2\mathbf{j}; \quad \mathbf{a} = \frac{d\mathbf{v}}{dt} = t\mathbf{j};$$

$$v = |\mathbf{v}| = \sqrt{4 + \frac{1}{4}t^4} = \frac{1}{2}\sqrt{16 + t^4}; \quad a = |\mathbf{a}| = |t|.$$

Hence  $4v^2 = 16 + t^4 = 16 + a^4$ , as required.

### Solution 3.7

(a) Using the dot notation for time derivatives where appropriate, with position vector  $\mathbf{r} = r\mathbf{e}_r$ , the velocity is

$$\mathbf{v} = \dot{\mathbf{r}} = \frac{d}{dt}(r\mathbf{e}_r) = \dot{r}\mathbf{e}_r + r\dot{\mathbf{e}}_r.$$

(Note that  $\mathbf{e}_r$  is *not* a constant vector.) Now

$$\mathbf{e}_r = \cos\theta\mathbf{i} + \sin\theta\mathbf{j}, \quad \mathbf{e}_\theta = -\sin\theta\mathbf{i} + \cos\theta\mathbf{j}, \quad \text{so}$$

$$\dot{\mathbf{e}}_r = -\sin\theta\dot{\theta}\mathbf{i} + \cos\theta\dot{\theta}\mathbf{j} = \dot{\theta}\mathbf{e}_\theta.$$

Hence

$$\mathbf{v} = \dot{r}\mathbf{e}_r + r\dot{\theta}\mathbf{e}_\theta.$$

Also

$$\dot{\mathbf{e}}_\theta = -\cos\theta\dot{\theta}\mathbf{i} - \sin\theta\dot{\theta}\mathbf{j} = -\dot{\theta}\mathbf{e}_r, \quad \text{and so}$$

$$\mathbf{a} = \dot{\mathbf{v}} = (\ddot{r} - r\dot{\theta}^2)\mathbf{e}_r + (r\ddot{\theta} + 2\dot{r}\dot{\theta})\mathbf{e}_\theta.$$

(b) We have  $r = r_0$  (constant) for a particle moving in a circle (taking the origin to be at the centre of the circle), so that  $\dot{r} = 0$  and  $\ddot{r} = 0$ . The position vector is  $\mathbf{r} = r_0\mathbf{e}_r$ . From part (a), the velocity vector is

$$\mathbf{v} = r_0\dot{\theta}\mathbf{e}_\theta = r_0\omega\mathbf{e}_\theta,$$

where  $\dot{\theta} = \omega$  is constant because the speed  $|\mathbf{v}| = |r_0\dot{\theta}|$  is constant. The acceleration vector is

$$\mathbf{a} = -r_0\omega^2\mathbf{e}_r,$$

because  $\ddot{\theta} = \dot{\omega} = 0$ .

Both of  $\mathbf{a}$  and  $\mathbf{r}$  are multiples of  $\mathbf{e}_r$ , and so are parallel. Also  $\mathbf{v} \cdot \mathbf{r} = 0$  (since  $\mathbf{e}_\theta \cdot \mathbf{e}_r = 0$ ), and so  $\mathbf{v}$  and  $\mathbf{r}$  are perpendicular.

### Solution 3.8

$$(a) \frac{\partial\phi}{\partial x} = 6xy; \quad \frac{\partial\phi}{\partial y} = 3x^2 - 3y^2z^2; \quad \frac{\partial\phi}{\partial z} = -2y^3z.$$

$$(b) \mathbf{grad} \phi = 6xy\mathbf{i} + 3(x^2 - y^2z^2)\mathbf{j} - 2y^3z\mathbf{k}$$

$$(c) \text{At } (1, 2, -1), \quad \mathbf{grad} \phi = 12\mathbf{i} - 9\mathbf{j} + 16\mathbf{k}.$$

### Solution 3.9

$$(a) \mathbf{grad} \phi = (2z^2 - 3y - 4)\mathbf{i} - 3x\mathbf{j} + 4xz\mathbf{k}$$

$$\text{At } (1, -1, 2), \quad \mathbf{grad} \phi = 7\mathbf{i} - 3\mathbf{j} + 8\mathbf{k}.$$

$$(b) \mathbf{grad} \phi = (2xyz + 4z^2)\mathbf{i} + x^2z\mathbf{j} + (x^2y + 8xz)\mathbf{k}$$

$$\text{At } (1, -2, -1), \quad \mathbf{grad} \phi = 8\mathbf{i} - \mathbf{j} - 10\mathbf{k}.$$

### Solution 3.10

(a) The maximum rate of change of  $\phi$  is  $|\mathbf{grad} \phi|$  in the direction of  $\mathbf{grad} \phi$ . At  $(1, -2, -1)$ , we have (from Solution 3.9(b))

$$\mathbf{grad} \phi = 8\mathbf{i} - \mathbf{j} - 10\mathbf{k} \quad \text{and so} \quad |\mathbf{grad} \phi| = \sqrt{165}.$$

(b) The rate of change of  $\phi$  in the direction of  $\mathbf{e}$  is  $\mathbf{grad} \phi \cdot \mathbf{e}$ . At the point  $(1, 0, 1)$ , we have

$$\mathbf{grad} \phi = 4\mathbf{i} + \mathbf{j} + 8\mathbf{k} \quad \text{and so} \quad \mathbf{grad} \phi \cdot \mathbf{e} = \frac{13}{3}\sqrt{3}.$$

(c) The gradient of  $\phi$  evaluated at the point  $(1, 1, 2)$  is normal to the surface  $\phi = 18$ . The direction of the normal is that of the vector

$$\mathbf{grad} \phi = 20\mathbf{i} + 2\mathbf{j} + 17\mathbf{k}.$$

### Solution 3.11

$$(a) (i) \frac{du}{dt} = 6t^5 + 4t^3 + 2t - 2$$

$$(ii) \mathbf{grad} u = 2t^2\mathbf{i} + 2(t-1)\mathbf{j} + 2t^3\mathbf{k}$$

$$(iii) \frac{d\mathbf{r}}{dt} = 2t\mathbf{i} + \mathbf{j} + 3t^2\mathbf{k}$$

$$(b) \mathbf{grad} u \cdot \frac{d\mathbf{r}}{dt} = 4t^3 + 2(t-1) + 6t^5.$$

This is the same as  $du/dt$  in part (a)(i).

### Comment

This is true in all cases since, applying the Chain Rule for  $u(x, y, z)$ , where  $x = x(t)$ ,  $y = y(t)$ ,  $z = z(t)$ , we have

$$\frac{du}{dt} = \frac{\partial u}{\partial x} \frac{dx}{dt} + \frac{\partial u}{\partial y} \frac{dy}{dt} + \frac{\partial u}{\partial z} \frac{dz}{dt} = \mathbf{grad} u \cdot \frac{d\mathbf{r}}{dt}.$$

### Solution 3.12

$$(a) \operatorname{div} \mathbf{F} = \frac{\partial}{\partial x}(xz^3) + \frac{\partial}{\partial y}(-2x^2yz) + \frac{\partial}{\partial z}(2yz^4) \\ = z^3 - 2x^2z + 8yz^3$$

At  $(1, 1, -1)$ , we have

$$\operatorname{div} \mathbf{F} = (-1) - 2 \times 1 \times (-1) + 8 \times 1 \times (-1) = -7.$$

$$(b) \operatorname{curl} \mathbf{F} = \begin{vmatrix} \mathbf{i} & \mathbf{j} & \mathbf{k} \\ \partial/\partial x & \partial/\partial y & \partial/\partial z \\ xz^3 & -2x^2yz & 2yz^4 \end{vmatrix}$$

$$(c) \operatorname{curl} \mathbf{F} = (2z^4 + 2x^2y)\mathbf{i} + 3xz^2\mathbf{j} - 4xyz\mathbf{k}$$

(d) At  $(1, 1, -1)$ , we have

$$\operatorname{curl} \mathbf{F} = (2 \times 1 + 2 \times 1 \times 1)\mathbf{i} + (3 \times 1 \times 1)\mathbf{j} \\ - (4 \times 1 \times 1 \times (-1))\mathbf{k} \\ = 4\mathbf{i} + 3\mathbf{j} + 4\mathbf{k}.$$

### Solution 3.13

$$(a) \operatorname{div} \mathbf{F} = -x^2 + 2xz$$

$$\text{At } (1, 1, 1), \quad \operatorname{div} \mathbf{F} = 1.$$

$$\operatorname{curl} \mathbf{F} = (2y - z^2)\mathbf{j} - 2(xy + z)\mathbf{k}$$

$$\text{At } (1, 1, 1), \quad \operatorname{curl} \mathbf{F} = \mathbf{j} - 4\mathbf{k}.$$

$$(b) \operatorname{div} \mathbf{F} = 2x + z$$

$$\text{At } (2, -1, 0), \quad \operatorname{div} \mathbf{F} = 4.$$

$$\text{curl } \mathbf{F} = -(x+y)\mathbf{i} + y\mathbf{j}$$

$$\text{At } (2, -1, 0), \quad \text{curl } \mathbf{F} = -\mathbf{i} - \mathbf{j}.$$

$$(c) \quad \text{div } \mathbf{F} = 3yz^2 + 6xy^2 - x^2y$$

$$\text{At } (-1, 1, 2), \quad \text{div } \mathbf{F} = 5.$$

$$\text{curl } \mathbf{F} = -x^2z\mathbf{i} + 8xyz\mathbf{j} + (2y^3 - 3xz^2)\mathbf{k}$$

$$\text{At } (-1, 1, 2), \quad \text{curl } \mathbf{F} = -2\mathbf{i} - 16\mathbf{j} + 14\mathbf{k}.$$

## Section 4

### Solution 4.1

(a) The equations  $x = a \cos t$  and  $y = a \sin t$  can be used as a parametrisation for the circle. The values  $t = 0$  and  $t = 2\pi$  will describe beginning and end points of the circle, and will be used as limits for the integration over  $t$  in part (c). (Any other choice for which the beginning and end points are the same is also valid.)

$$\begin{aligned} (b) \quad \mathbf{F} &= y(2xy - 1)\mathbf{i} + x(2xy + 1)\mathbf{j} \\ &= a \sin t (2a^2 \sin t \cos t - 1)\mathbf{i} \\ &\quad + a \cos t (2a^2 \sin t \cos t + 1)\mathbf{j} \end{aligned}$$

$$\mathbf{r} = x\mathbf{i} + y\mathbf{j} = a \cos t \mathbf{i} + a \sin t \mathbf{j}$$

$$\frac{d\mathbf{r}}{dt} = -a \sin t \mathbf{i} + a \cos t \mathbf{j}$$

$$\begin{aligned} \mathbf{F} \cdot \frac{d\mathbf{r}}{dt} &= -a^2 \sin^2 t (2a^2 \sin t \cos t - 1) \\ &\quad + a^2 \cos^2 t (2a^2 \sin t \cos t + 1) \\ &= a^4 \sin(2t)(\cos^2 t - \sin^2 t) + a^2(\cos^2 t + \sin^2 t) \\ &= a^4 \sin(2t) \cos(2t) + a^2 = \frac{1}{2}a^4 \sin(4t) + a^2 \end{aligned}$$

$$\begin{aligned} (c) \quad \oint_C \mathbf{F} \cdot d\mathbf{r} &= \int_{t=0}^{t=2\pi} \mathbf{F} \cdot \frac{d\mathbf{r}}{dt} dt \\ &= \int_0^{2\pi} \left( \frac{1}{2}a^4 \sin(4t) + a^2 \right) dt \\ &= \left[ -\frac{1}{8}a^4 \cos(4t) + a^2 t \right]_0^{2\pi} = 2\pi a^2 \end{aligned}$$

### Solution 4.2

$$(a) \quad \int_C \mathbf{F} \cdot d\mathbf{r} = \int_0^{\pi/2} (-8 \cos t \sin t - 4 \sin^2 t - 4 \cos^2 t) dt = -2\pi - 4$$

(The parametrisation used is  $x = 2 \cos t$ ,  $y = 2 \sin t$ .)

$$(b) \quad \int_C \mathbf{F} \cdot d\mathbf{r} = \int_1^2 (3t^2 - 4t + 5) dt = 6$$

$$\begin{aligned} (c) \quad \mathbf{F} &= \text{grad } \phi \\ &= 2xyz\mathbf{i} + (x^2z + z^3)\mathbf{j} + (x^2y + 3yz^2)\mathbf{k}, \quad \text{so} \\ \int_C \mathbf{F} \cdot d\mathbf{r} &= \int_0^1 8t^3 dt = 2. \end{aligned}$$

(The parametrisation used is  $x = t$ ,  $y = t$ ,  $z = t$ .)

Check:

$$\begin{aligned} \int_{AB} \text{grad } \phi \cdot d\mathbf{r} &= \int_{AB} \text{grad } \phi \cdot \frac{d\mathbf{r}}{dt} dt \\ &= \int_{AB} \frac{d\phi}{dt} dt = \phi(B) - \phi(A) \\ &= \phi(1, 1, 1) - \phi(0, 0, 0) = 2 \end{aligned}$$

### Solution 4.3

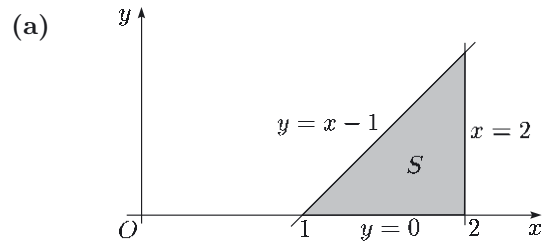

(b) The minimum and maximum values of  $x$  are  $x = 1$  and  $x = 2$  (that is,  $a = 1$  and  $b = 2$ ).

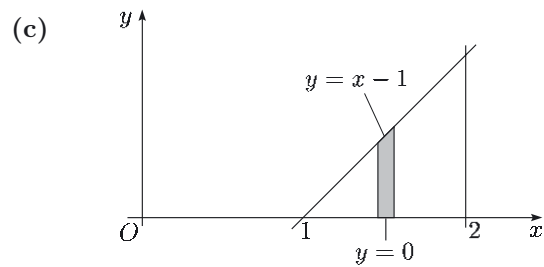

$$(d) \quad \int_S (x^2 + y^2) dA = \int_{x=1}^{x=2} \left( \int_{y=0}^{y=x-1} (x^2 + y^2) dy \right) dx$$

$$\begin{aligned} (e) \quad \int_{y=0}^{y=x-1} (x^2 + y^2) dy &= \left[ x^2 y + \frac{1}{3} y^3 \right]_{y=0}^{y=x-1} \\ &= x^2(x-1) + \frac{1}{3}(x-1)^3 \end{aligned}$$

$$\begin{aligned} (f) \quad \int_{x=1}^{x=2} (x^3 - x^2 + \frac{1}{3}(x-1)^3) dx \\ = \left[ \frac{1}{4}x^4 - \frac{1}{3}x^3 + \frac{1}{12}(x-1)^4 \right]_{x=1}^{x=2} = \frac{3}{2} \end{aligned}$$

### Solution 4.4

$$\begin{aligned} (a) \quad \int_S f(x, y) dA &= \int_{x=0}^{x=a} \left( \int_{y=0}^{y=b} (p_0 + \rho_0 g(h_0 + x)) dy \right) dx \\ &= b \int_{x=0}^{x=a} (p_0 + \rho_0 g(h_0 + x)) dx \\ &= ab(p_0 + \rho_0 g(h_0 + \frac{1}{2}a)) \end{aligned}$$

$$\begin{aligned} (b) \quad \int_S f(x, y) dA &= \int_{x=0}^{x=2} \left( \int_{y=x^2}^{y=4x-x^2} (x-y) dy \right) dx \\ &= \int_{x=0}^{x=2} (2x^3 - 4x^2) dx = -\frac{8}{3} \end{aligned}$$

### Solution 4.5

$$(a) \quad \oint_C \mathbf{F} \cdot d\mathbf{r} = \int_0^{2\pi} (-4 \sin^2 t + 16 \cos^3 t \sin t) dt = -4\pi$$

(The parametrisation used is  $x = 2 \cos t$ ,  $y = 2 \sin t$ .)

$$\begin{aligned} (b) \quad \int_S (\text{curl } \mathbf{F}) \cdot \mathbf{k} dA \\ = \int_{x=-2}^{x=2} \left( \int_{y=-\sqrt{4-x^2}}^{y=\sqrt{4-x^2}} (2xy - 1) dy \right) dx \\ = -2 \int_{x=-2}^{x=2} \sqrt{4-x^2} dx = -4\pi \end{aligned}$$

(The final integral can be evaluated using the substitution  $x = 2 \cos u$ . Alternatively, the surface integral could be evaluated using polar coordinates.)

**Comment**

This equality of integrals is an example of *Stokes' Theorem*, which will be introduced in *Unit 4*.

**Solution 4.6**

(a) (i)

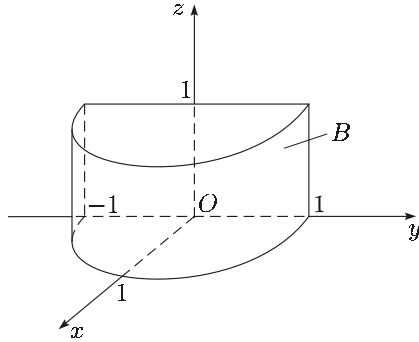

(ii)

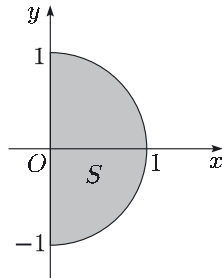

(b)

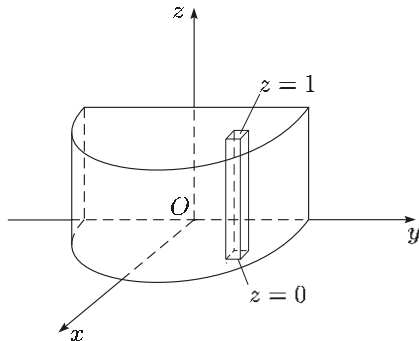

(c)  $\int_{z=0}^{z=1} xz \, dz = x \left[ \frac{1}{2} z^2 \right]_{z=0}^{z=1} = \frac{1}{2} x \quad (= g(x, y))$

(d)

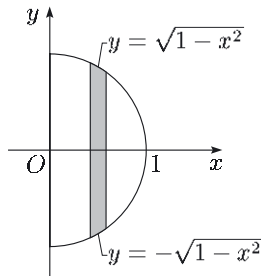

$$\begin{aligned} \int_S g(x, y) \, dA &= \int_{x=0}^{x=1} \left( \int_{y=-\sqrt{1-x^2}}^{y=\sqrt{1-x^2}} \frac{1}{2} x \, dy \right) dx \\ &= \int_{x=0}^{x=1} \frac{1}{2} x [y]_{y=-\sqrt{1-x^2}}^{y=\sqrt{1-x^2}} dx \\ &= \int_{x=0}^{x=1} x \sqrt{1-x^2} \, dx \\ &= \left[ -\frac{1}{3} (1-x^2)^{3/2} \right]_0^1 = \frac{1}{3} \end{aligned}$$

**Solution 4.7**

(a)  $\int_{z=0}^{z=1} (x + y + z) \, dz = x + y + \frac{1}{2}$

$$\begin{aligned} \int_B (x + y + z) \, dV &= \int_{x=0}^{x=1} \left( \int_{y=0}^{y=1} (x + y + \frac{1}{2}) \, dy \right) dx \\ &= \int_{x=0}^{x=1} (x + 1) \, dx = \frac{3}{2} \end{aligned}$$

(b)  $\int_{z=0}^{z=1} (z + 3x - 2) \, dz = 3x - \frac{3}{2}$

$$\begin{aligned} \int_B (z + 3x - 2) \, dV &= \int_{x=0}^{x=2} \left( \int_{y=0}^{y=x} (3x - \frac{3}{2}) \, dy \right) dx \\ &= \int_{x=0}^{x=2} (3x^2 - \frac{3}{2}x) \, dx = 5 \end{aligned}$$

**Section 5**

**Solution 5.1**

(a) Since pressure is force per unit area, where [force] =  $MLT^{-2}$  and [area] =  $L^2$ , we have

$$[\text{pressure}] = \frac{[\text{force}]}{[\text{area}]} = \frac{MLT^{-2}}{L^2} = ML^{-1}T^{-2}.$$

Since density is mass per unit volume, and [volume] =  $L^3$ , we have

$$[\text{density}] = \frac{[\text{mass}]}{[\text{volume}]} = \frac{M}{L^3} = ML^{-3}.$$

(b) We have  $R = p/(\rho\Theta)$ , where  $[p] = ML^{-1}T^{-2}$ ,  $[\rho] = ML^{-3}$  and  $[\Theta] = \Theta$ . Hence

$$[R] = \frac{[p]}{[\rho][\Theta]} = \frac{ML^{-1}T^{-2}}{(ML^{-3})\Theta} = L^2T^{-2}\Theta^{-1}.$$

**Solution 5.2**

Since acceleration has SI units  $ms^{-2}$ ,

$$[\text{acceleration}] = LT^{-2}.$$

Since kinetic energy is  $\frac{1}{2} \times \text{mass} \times \text{speed}^2$ ,

$$[\text{kinetic energy}] = M(LT^{-1})^2 = ML^2T^{-2}.$$

**Solution 5.3**

We have  $G = Fr^2/(m_1m_2)$ , where  $[F] = MLT^{-2}$ ,  $[r] = L$ ,  $[m_1] = [m_2] = M$ . Hence

$$[G] = \frac{[F][r]^2}{[m_1][m_2]} = \frac{(MLT^{-2})L^2}{M^2} = M^{-1}L^3T^{-2}.$$

**Solution 5.4**

(a) We have  $[F] = \text{MLT}^{-2}$ ,  $[v] = \text{LT}^{-1}$ ,  $[r] = \text{L}$ ,  
 $[\rho] = \text{ML}^{-3}$ ,  $[\mu] = \text{ML}^{-1}\text{T}^{-1}$ .

(b) Taking  $F = k v^\alpha r^\beta \rho^\gamma \mu^\delta$ , we have

$$[F] = [v]^\alpha [r]^\beta [\rho]^\gamma [\mu]^\delta.$$

(c) From step (a), this becomes

$$\begin{aligned} \text{MLT}^{-2} &= (\text{LT}^{-1})^\alpha \text{L}^\beta (\text{ML}^{-3})^\gamma (\text{ML}^{-1}\text{T}^{-1})^\delta \\ &= \text{M}^{\gamma+\delta} \text{L}^{\alpha+\beta-3\gamma-\delta} \text{T}^{-\alpha-\delta}. \end{aligned}$$

Equating powers of M, L and T in turn gives

$$\text{M: } 1 = \gamma + \delta, \quad \text{L: } 1 = \alpha + \beta - 3\gamma - \delta,$$

$$\text{T: } -2 = -\alpha - \delta.$$

(d) Expressing  $\beta$ ,  $\gamma$ ,  $\delta$  in terms of  $\alpha$ , we obtain

$$\beta = \alpha, \quad \gamma = -1 + \alpha, \quad \delta = 2 - \alpha.$$

(e) From step (b), we have

$$F = k v^\alpha r^\alpha \rho^{-1+\alpha} \mu^{2-\alpha} = \frac{k\mu^2}{\rho} \left( \frac{vr\rho}{\mu} \right)^\alpha.$$

(f) We deduce that a possible form for  $F$  is

$$F = \frac{\mu^2}{\rho} h \left( \frac{vr\rho}{\mu} \right),$$

where  $h$  is an undetermined function.

**Comment**

The dimensionless group  $vr\rho/\mu$  is known as the *Reynolds number* for this situation. You will see more about this in *Units 7* and *8*.

**Solution 5.5**

$$\tau = h(\Phi) \sqrt{\frac{l}{g}},$$

where  $h$  is an undetermined function.

# *Index*

- absolute temperature 26
- auxiliary equation 7
  
- base dimensions 25
  
- Chain Rule 13
- complementary function 7
- curl (of vector field) 19
  
- density 26
- differential equation 3, 5, 7
  - constant-coefficient 7
  - general solution 3–5
    - explicit form 3, 5
    - implicit form 3, 5
  - homogeneous 7
  - inhomogeneous 7
  - linear 5, 7
  - non-linear 3
  - of first order 3, 5
  - of second order 7
  - particular solution 3, 4
- dimensional analysis 27
- dimensional consistency 26
- dimensionless 27
- dimensionless group 27
- dimensions 26
- divergence (of vector field) 19
- drag force 28
  
- gas constant 26
- gradient (of scalar field) 18
  
- integrating factor 5
- integrating factor method 5
  
- kinetic energy 26
  
- Newtonian (dot) notation 17
  
- parametrise 20
  
- partial derivatives 10
- particular integral 8
- pathline 16
- pendulum 28
- polar coordinates 17
- pressure 26
  
- range 27
- Reynolds number 35
  
- scalar field 18
- scalar line integral 20
- separation of variables 3
- shear force 25
- speed 16
- Stokes' Theorem 34
- surface integral 22
  
- Taylor polynomial (second-order) 11
- trial function 8
  
- universal gravitational constant 26
  
- variables separated 3
- vector 14
  - acceleration 16
  - addition 14
  - cosine of angle between two 14
  - length 14
  - magnitude 14
  - position 16
  - scalar (dot) product 14
  - scalar triple product 15
  - tangent 16
  - unit 16
  - vector (cross) product 14
    - determinant notation 14
  - velocity 16
- vector field 19
- viscosity 25
- volume integral 23